

**FLUOROPOLYMER  
HOSE  
ASSEMBLY  
SPECIFICATION  
GUIDELINES**



**NAHAD**

THE ASSOCIATION FOR HOSE AND  
ACCESSORIES DISTRIBUTION

**NAHAD 800**  
2005

**IMPORTANT NOTE TO READER:**

**NAHAD - The Association for Hose and Accessories Distribution** - is pleased to provide this *comprehensive set of basic Hose Assembly Specification Guidelines* for customers seeking to acquire fabricated hose assemblies for various industrial applications. The information contained within this document has been developed through the concerted efforts of dozens of member volunteers, association staff and industry leaders, with the common goal of helping to improve the safety, quality and reliability of fabricated hose assemblies.

In addition to this document, NAHAD has produced four other Hose Assembly Specification Guidelines publications, addressing a total of five hose product groups, including: Composite Hose; Corrugated Metal Hose; Hydraulic Hose; Industrial Hose and Fluoropolymer Hose. These five publications are intended to complement existing industry and federal regulations. Aerospace and hydraulic brake hose assemblies are specifically excluded from this and the other four documents.

Hose, hose fittings and hose couplings come in various sizes and designs. Although there are standards published by manufacturers and independent testing organizations, such as ANSI, ASME, ASTM, ASQ, UL, ISO, SAE, RMA and others which relate to hoses and hose fittings, there are no generally recognized standards for hose assemblies. This publication is indebted to these organizations and, in specific cases, refers the reader to designated existing standards and recommendations provided by these other sources in an attempt to encourage the fabrication of safer, higher quality and more reliable hose assemblies.

NAHAD has published these Hose Assembly Specification Guidelines in order to create reference works that compile information of value to NAHAD members, manufacturers and customers in developing hose assemblies that meet specific individual needs. To the extent that each assembly has unique characteristics, it must be custom designed, engineered and tested. Hopefully, these Guidelines will be useful in the process.

In compiling standards and recommendations published by others and in developing these Guidelines, NAHAD has not and will not engage in independent testing or verification of the information provided to it. Users of these Guidelines should not, and cannot, rely on these Guidelines as a standard, certification or approval of the data published herein. NAHAD, and the member company volunteers, association staff and industry leaders who participated in the creation of these Guidelines do not assume, and expressly decline and deny, any and all liability for any product failures, damages or injuries that may result in any way from utilization of these Guidelines or products based on these Guidelines.

The NAHAD Hose Assembly Guidelines incorporate various technical recommendations published by other sources. NAHAD has not independently verified these recommendations and specifically disclaims any and all liability, direct or indirect, for any failures, damages or injuries resulting in whole or in part from the failure of any product, including hoses, fittings, and assemblies described in this publication or in the Guidelines.

© Copyright 2005 by The Association For Hose & Accessories Distribution, Inc. (NAHAD). All rights reserved. No part of this publication may be reproduced, stored in a retrieval system, or transcribed, in any form or by any means, electronic, mechanical, photocopying or otherwise, without the prior written permission of NAHAD.

Published by The Association For Hose & Accessories Distribution, Inc.  
105 Eastern Avenue, Suite 104  
Annapolis, Maryland 21403  
[www.nahad.org](http://www.nahad.org)



## Table of Contents

<b>Section 1 – Scope</b> .....	7
<b>Section 2 – Application Requirements – STAMPED</b> .....	7
<b>2.1 Purpose</b> .....	7
<b>2.2 General</b> .....	7
<b>2.3 Critical Applications</b> .....	8
2.3.1 Chlorine.....	8
<b>2.4 Directions</b> .....	8
<b>Section 3 – Hose of Fluoropolymer</b> .....	11
<b>3.1 Scope</b> .....	11
<b>3.2 Materials</b> .....	11
<b>3.2.1 Purpose</b> .....	11
<b>3.2.2 General</b> .....	11
<b>3.2.3 Hose Construction Components</b> .....	11
<b>3.2.4 Types of construction</b> .....	12
<b>3.3 Assembly Dimensions</b> .....	13
<b>3.3.1 Purpose</b> .....	13
<b>3.3.2 Metric / English Measurement System</b> .....	13
<b>3.3.3 Inside Diameter of the Hose</b> .....	14
<b>3.3.4 Developed Lengths</b> .....	14
<b>3.3.5 Method of Measurement</b> .....	14
<b>3.4 Hose Construction</b> .....	15
<b>3.4.1 Purpose</b> .....	15
<b>3.4.2 Metallic Hose with a Smooth Liner of Fluoropolymer</b> .....	15
<b>3.4.3 Geometric Construction</b> .....	15
<b>3.5 Performance Characteristics</b> .....	16
<b>3.5.1 Purpose</b> .....	16
<b>3.5.2 Maximum allowable Working Pressure (MAWP)</b> .....	16
<b>3.5.3 Temperature</b> .....	16
<b>3.5.4 Chemical Compatibility</b> .....	16
<b>3.5.5 Minimum Bend Radius</b> .....	16
<b>3.5.6 Vacuum Rating</b> .....	16
<b>3.6 Hose Assembly Length Determination For Various Movements</b> .....	17
<b>3.6.1 Purpose</b> .....	17
<b>3.6.2 Definitions of Symbols</b> .....	17
<b>3.6.3 Example Values</b> .....	17
<b>3.6.4 Constant Radius Traveling Loop</b> .....	18
<b>3.6.5 Variable Radius Traveling Loop</b> .....	19
<b>3.6.6 Offset Motion</b> .....	21
<b>3.6.7 Angular Motion</b> .....	22
<b>3.6.8 Vertical Loop with Movement in Two Directions</b> .....	23
<b>3.7 Assembly Methods</b> .....	23
<b>3.7.1 Purpose</b> .....	23
<b>3.7.2 Crimp Method</b> .....	23
<b>3.7.3 Swage Method</b> .....	24

3.7.4 Flared Over Tubes of Fluoropolymer (Convolut ed & Smooth).....	24
<b>Section 4 – Testing Procedures .....</b>	<b>25</b>
4.1 Purpose .....	25
4.2 Hydrostatic Pressure Tests.....	25
4.3 Pneumatic Pressure Test – Fluoropolymer hose .....	27
4.4 Other Leakage Tests.....	27
4.5 Electrical Continuity Test .....	27
4.6 Electrical Resistance Test - UL330 Testing Method for an Assembly.....	27
4.7 Visual Inspection.....	28
4.8 Calibrations .....	28
4.9 Test Documentation .....	29
4.10 Other Documentation.....	29
4.10.1 Certificate of Conformance.....	29
4.10.2 Test Report.....	30
4.10.3 Certified Material Test Reports .....	30
4.10.4 Third Party Certification .....	30
<b>Section 5 – Quality Plan .....</b>	<b>30</b>
5.1 Purpose .....	30
5.2 Sampling Plan .....	31
5.3 Material Receiving Inspection .....	32
5.3.1 Couplings.....	32
5.3.2 Hose.....	32
5.4 Storage (Labeling, Environment, Time).....	33
<b>Section 6 – Assembly Identification, Cleaning and Packaging.....</b>	<b>33</b>
6.1 Purpose .....	33
6.2 Hose Assembly Markings.....	33
6.2.1 Method of Marking .....	33
6.3 Cleaning .....	34
6.4 Packaging .....	34
<b>Section 7 – Installation and Handling.....</b>	<b>34</b>
7.1 Purpose .....	34
7.2 General.....	35
7.3 Safety Considerations.....	35
7.3.1 Media Permeation .....	35
7.3.2 Fluid Injections .....	35
7.3.3 Whipping Hose .....	35
7.3.4 Fire and Explosions from Conveyed Fluids .....	36
7.3.5 Fire and Explosions from Static-Electric Discharge.....	36
7.3.6 Burns from Conveyed Fluids.....	36
7.3.7 Electrical Shock.....	36
7.3.8 Fluid Controlled Mechanisms.....	37
7.3.9 Air and Gaseous Applications.....	37
7.4 Hose Installation and Replacement.....	37
7.4.1 Pre-Installation Inspection .....	37
7.4.2 Handling During Installation .....	37
7.4.3 Torque .....	38

<b>7.4.4 Hose Routing</b> .....	38
<b>7.4.5 Securement and Protection</b> .....	38
<b>7.4.6 System Checkouts</b> .....	38
<b>7.5 Maintenance Inspection</b> .....	38
<b>7.5.1 Inspection Frequency</b> .....	38
<b>7.5.2 Visual Inspections</b> .....	39
<b>7.5.3 Visual Inspections for All Other Components</b> .....	39
<b>7.5.4 Functional Tests</b> .....	39
<b>APPENDIX A – Pressure Conversion Chart</b> .....	40
<b>APPENDIX B – References</b> .....	41
<b>APPENDIX C – Hose Ends</b> .....	44
<b>APPENDIX D – Glossary</b> .....	53



## Section 1 – Scope

This guideline is intended to complement existing industry standards and federal regulations. This document **identifies guidelines** necessary for the selection of components, fabrication, and testing of hose **fluoropolymer** assemblies.

Fluoropolymer lined hose is often referred to as Teflon® hose. Teflon® is a brand name and a registered trademark of E.I. DuPont and is only one manufacturer of Fluoropolymer materials. This section is not limited to the use of PTFE as a liner material, PFA and FEP are also commonly used as liner options for Fluoropolymer hoses.

Here are some key considerations when choosing a hose liner to best suit your application;

- Flex Life
- Temperature
- Tensile strength
- Chemical compatibility
- Cost

This document is not intended to prohibit either supplier or customer from attaching additional requirements for hose, couplings or hose assemblies, if necessary, to satisfy the application. It is the responsibility of the fabricator and user to separately qualify these applications and their unique requirements necessary to ensure performance capability.

## Section 2 – Application Requirements – STAMPED

### 2.1 Purpose

The purpose of this section is to provide a simple to use guide to assist in determining the correct hose, coupling and attachment method that will satisfy your customer's needs. Please note that Section 2.3 addresses Critical Applications which may require special attention.

### 2.2 General

The guide uses the STAMPED process. STAMPED is an acronym and stands for the 7 major information areas required to provide a quality hose assembly for your customer, as follows:



**S** stands for **SIZE**; I.D., O.D. and length

**T** stands for **TEMPERATURE** of the material conveyed and environmental

**A** stands for the **APPLICATION**, the conditions of use

**M** stands for the **MATERIAL** being conveyed, type and concentration

**P** stands for the **PRESSURE** to which the assembly will be exposed

**E** stands for **ENDS**; style, type, orientation, attachment methods, etc.

**D** stands for **DELIVERY**; testing, quality, packaging, and delivery requirements

## ***2.3 Critical Applications***

There are specific applications that require additional design, fabrication installation and maintenance considerations over and above the requirements set forth in these Hose Assembly Guidelines. The following is a non-inclusive list.

### **2.3.1 Chlorine**

For hose assemblies used to transport chlorine, there are specific requirements set forth in the Chlorine Institute Pamphlet #6 (edition 15), [Piping Systems for Dry Chlorine](#), Appendix A, Section 9. Please note that Chlorine transfer hose (CTH) must be clearly and permanently marked as per [Chlorine Institute Pamphlet #6 \(edition 15\), Appendix A, Section 9](#). These permanent markings (e.g. stamping, stenciling or coding) should be utilized throughout the supply chain for purposes of continuous positive identification.

### **2.3.2 Anhydrous Ammonia**

### **2.3.3 Aircraft Fueling**

### **2.3.4 Welding Hose**

### **2.3.5 LP Gas**

## **2.4 Directions**

Using the form:

1. Inform the customer you will be using an application format called STAMPED.
2. Ask your customer the pertinent questions outlined on the form, in sequence.

3. After completing the form, ask your customer to confirm their answers as you repeat them, in sequence.

4. Provide the completed format to your assembly area or order entry as required

The following list of special considerations may help to clarify application parameters:

1. Abrasion
2. Electrical conductivity
3. Environment
4. Flammability
5. Flow rate
6. Fluid velocity
7. Movement (type, distance, frequency)
8. Ozone
9. Permeation (vapor conveying hose)
10. Routing
11. Salt water
12. Static electricity
13. Ultraviolet light
14. Vibration (frequency rate . Hz, amplitude . "G" load)

(See **STAMPED** Form on next page)

**Customer Information:**

Company: \_\_\_\_\_  
 Contact: \_\_\_\_\_  
 Address: \_\_\_\_\_  
 Phone: \_\_\_\_\_

Fax: \_\_\_\_\_  
 E-mail: \_\_\_\_\_  
 P.O.#: \_\_\_\_\_  
 Terms: \_\_\_\_\_

Size	I.D.	O.D.	Overall Length	Tolerance

Temperature	Materials Conveyed		Environmental Temperature	
	Min.	Max	Min	Max
	°F/°C	°F/°C	°F/°C	°F/°C

Application	Type: _____
-------------	-------------

Material/ Media	Material Conveyed		
	Internal Media		External Environment

Pressure	Max Working Pressure	Spikes	Vacuum
	PSI/kPa	PSI/kPa	Inches of Hg/kPa

Ends	End	Style/ Material	Size	Threads/Bolts Hole Alignment	Orientation	Attachment Methods	Capped
	1						Y N
	2						Y N

Delivery	Quantity Required:		Date Required:
	Package Type:		
	Pick Up Date:		Ship Via:
	Testing Required:	Y N	Type:
	Certification Required:	Y N	Type:

**Special Requirements:**

## **Section 3 – Hose of Fluoropolymer**

### **3.1 Scope**

This section specifies the methods and requirements necessary for the design, fabrication and testing hose of Fluoropolymer assemblies.

This document pertains to diameters from 1/8 inch to 4 inches, except where limited by section.

The hose of Fluoropolymer assemblies specified are suitable for the major portion of commercial and industrial applications.

The following applications are *excluded* from the scope of this document:

- Installations involving axial compression or extension
- Extreme working pressures (above 3,500 psi)
- Extreme Temperature (above 500 F)
- Chlorine or Bromine applications
- High Purity
- Compressed Gas

This document is not intended to prohibit either supplier or customer from attaching additional requirements for hose of Fluoropolymer or hose of Fluoropolymer assemblies, if necessary to satisfy the application.

### **3.2 Materials**

#### **3.2.1 Purpose**

The purpose of this section is to identify the types of liners/inner cores most frequently used in the fabrication of hoses of Fluoropolymer. This information will guide you in the selection of the proper hoses of Fluoropolymer required for a specific application.

#### **3.2.2 General**

Hoses of Fluoropolymer are manufactured in several different configurations depending on the application. When selecting the hose, consideration must be given to corrosion resistance, service temperature, pressure ratings, end fittings, and exterior environmental conditions.(See S.T.A.M.P.E.D section)

#### **3.2.3 Hose Construction Components**

The following components comprise a hose of Fluoropolymer assembly. It is necessary to select the appropriate construction materials for the specific application.

A. Fluoropolymer Innercore (tube)

- PTFE
- PFA
- FEP

B. Reinforcements

- Braided, metallic.
- Braided, non-metallic
- Rubber, with/without wire/ fabric ply-core.
- Stainless Steel

C. Fittings

- Type 316 Stainless Steel
- Type 304 Stainless Steel
- Type 303/302 Stainless Steel
- Brass
- Carbon Steel (plated)
- Aluminum
- Non-Metallic
- Hastelloy ®
- Monel ®
- Alloy 20
- Encapsulated

D. Collars/Ferrules

- Stainless Steel
- Carbon Steel (plated)
- Brass
- Monel ®
- Hastelloy ®

### **3.2.4 Types of construction**

The hose construction may consist of one or more of the components listed below. Typically hoses of Fluoropolymer are reinforced by one of the following outer covers, however some applications do not require any

exterior reinforcement and the inner core alone may be adequate.  
(Consult manufacturer for specific limits.)

#### **3.2.4.1 Fluoropolymer Innercores (tube)**

- A. Smooth tube, extruded
- B. Convoluted
- C. Extruded, formed construction
- D. Tape wrapped, Fiberglass backed, molded convolution

#### **3.2.4.2 Reinforcements**

- A. Metallic (braided on, slip braided)
  - CRES (300 series)
  - Bronze
  - Monel.
  - Hastalloy
  - Others (consult manufacturer)
- B. Non-Metallic (braided on)
- C. Polypropylene
- D. PVDF
- E. Nylon
- F. Fiberglass
- G. Aramid Fibers

Others available. Consult the manufacturer.

The preceding specifications should be considered minimal and each manufacturer may suggest additional requirements to assure best results in fabrication, testing and service life.

### **3.3 Assembly Dimensions**

#### **3.3.1 Purpose**

The purpose of this section is to establish a standard method of measurement for hose of Fluoropolymer assemblies.

#### **3.3.2 Metric / English Measurement System**

The hose manufacturer shall state in their brochures or documentation which system will be employed in their manufacturing process. All tolerances will be applied to their system of measurement. Optional cross-

referencing of another system will be done in brackets. [e.g., 1/4 inch (6) means manufacture is in English and reference is to metric.]

### 3.3.3 Inside Diameter of the Hose

The inside diameter of the hose may be true bore or nominal bore as specified by the manufacturer.

### 3.3.4 Developed Lengths

Tolerances for the overall length of the hose assembly shall be observed according to the following table unless otherwise stated.

**Table 3.5.1 Tolerances**

This chart is intended for smooth bore hose. For other styles of hose, consult your manufacturer for actual tolerances.

Assembly Length Tolerances			
Inches		MM	
Up to 18+	+/- .125+(3.2 mm)	Up to 450 mm	+/- 3mm
18+to 36+	+/- .25+	450 mm to 900 mm	+/- 6 mm
36+to 50+	+/- .5+	900 mm to 1270 mm	+/- 13
Over 50+	+/- 1%	Over 1270 mm	+/- 1%

### 3.3.5 Method of Measurement

Normal length measurements shall be taken using a tape measure with the hose laying on a flat surface. If the centerline of the end connection is above the hose centerline, the hose should be supported accordingly. On most hose assemblies the developed length is the end to end dimension at the centerline (Figure 3.3.1). End connections with a seating face shall be measured from the seat face and not from the end of the fitting (e.g. JIC type end fittings) (Figure 3.3.2). Hose assemblies using elbows shall be measured from the centerlines (Figure 3.3.3).

**Figure 3.3.1 Measurement of Hose Assembly**

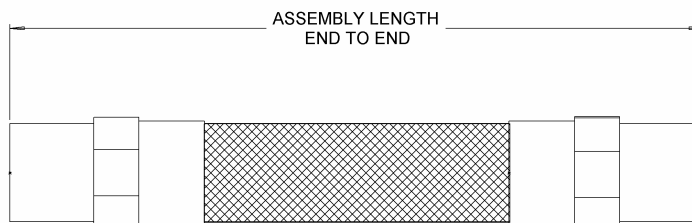

**Figure 3.3.2 Measurement of Hose Assembly having an End Connection with a Seating Face**

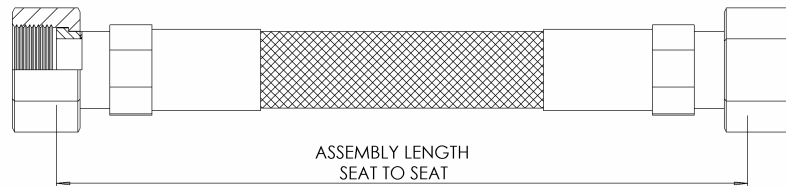

**Figure 3.3.3 Measurement of Hose Assembly having an Elbow Fitting**

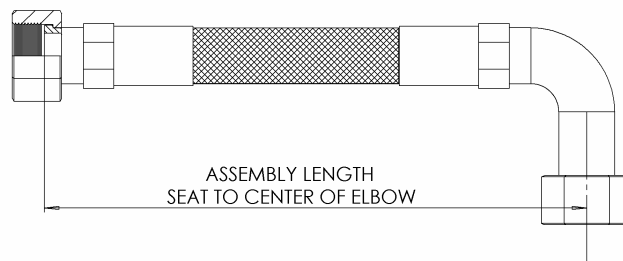

## 3.4 Hose Construction

### 3.4.1 Purpose

The purpose of the section is to define various hose of Fluoropolymer construction methods.

### 3.4.2 Metallic Hose with a Smooth Liner of Fluoropolymer

These are reinforced metal (stainless steel) corrugated hose assemblies designed to incorporate smooth liners of Fluoropolymer throughout the inside diameter of the hose and extending over the sealing surfaces of the fitting connections.

### 3.4.3 Geometric Construction

- A. The hose liner should consist of a smooth bore tube, concentric with consistent wall thickness throughout its length.
- B. Hose liner shall consist of convolutions of uniform height and pitch continuous along its length.



## **3.5 Performance Characteristics**

### **3.5.1 Purpose**

The purpose of this section is to establish various performance characteristics of hoses of Fluoropolymer assemblies.

### **3.5.2 Maximum allowable Working Pressure (MAWP)**

The MAWP for an assembly is 25% of its burst pressure.(see Glossary section)

### **3.5.3 Temperature**

Temperature directly affects MAWP. Most manufacturers rate maximum operating pressures at ambient temperatures. If a hose is to be considered for use in an application that exceeds ambient temperature, consult manufacturer for any pressure de-rating of the hose of Fluoropolymer assembly.

### **3.5.4 Chemical Compatibility**

For the corrosion resistance of the non-Fluoropolymer components of a hose assembly, consult the manufacturer or:

National Association of Corrosion Engineers Handbook  
1440 South Creek Drive  
Houston, TX 77084

### **3.5.5 Minimum Bend Radius**

A sphere with a diameter equal to 85% of the internal diameter of the hose must be able to roll freely (from end to end) in an unpressurized assembly bent 180 degrees at the hose's stated minimum bend radius. Other methods are also used by some manufacturers.

### **3.5.6 Vacuum Rating**

The maximum amount of vacuum that can be drawn on the inside of a hose assembly without causing the assembly to fail. For vacuum ratings in a bent application, consult the manufacturer.

## **3.6 Hose Assembly Length Determination For Various Movements**

### **3.6.1 Purpose**

The information in this section is provided as a guide to determine the overall length of hose assemblies for the conditions shown. All formulas determine the minimum live length required. To obtain the overall length, the length of the fittings including braid sleeves, must be added to the live length.

### **3.6.2 Definitions of Symbols**

The following definitions of symbols shall be used in all formulas:

- T = Travel
- R = Radius of the installation.
- L = Live length
- S = Outside diameter of the hose
- OAL = Overall length of the assembly
- MBR = Minimum bend radius of the hose

### **3.6.3 Example Values**

In all calculations, the following example values are assigned:

- Hose outside diameter (S) = 2.75+
- Minimum bend radius of hose (MBR) = 14+
- Fitting length including braid sleeve = 3.50+

### 3.6.4 Constant Radius Traveling Loop

**Figure 3.6.4.1 Constant Radius Traveling Loop - Vertical Travel**

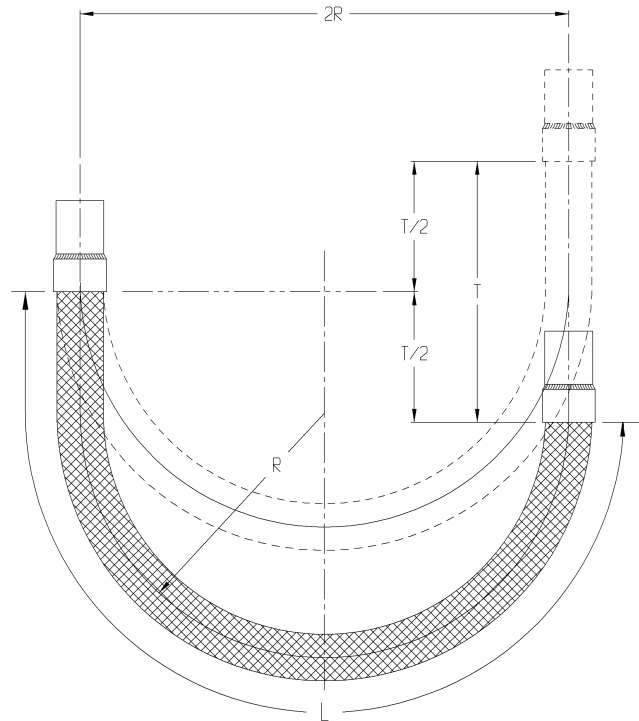

**Figure 3.6.4.2 Constant Radius Traveling Loop - Horizontal Travel**

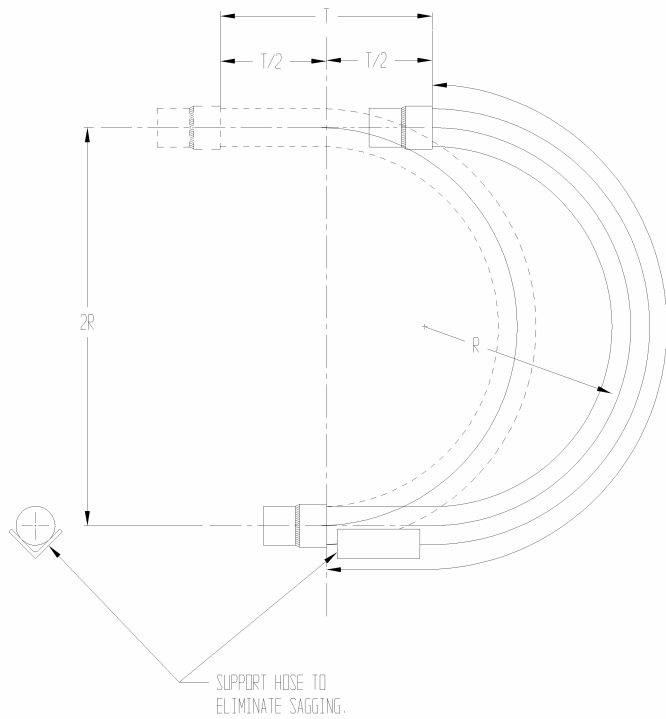

**Formula:**

$$L = 4(R) + (T)/2$$

Example: Travel (T) = 6.00+

$$2R = 40+R = 40+2 = 20+$$

$$L = 4(20+) + (6+)/2$$

$$L = 83.00+$$

$$OAL = 83.00++ 2(3.5+) = 90.00+$$

**Note:**

*For metal hose, R must be > or = MBR*

*For hose of Fluoropolymer, R must be > or = (MBR + S/2)*

**3.6.5 Variable Radius Traveling Loop**

**Figure 3.6.5.1 Variable Radius Traveling Loop - Vertical Travel**

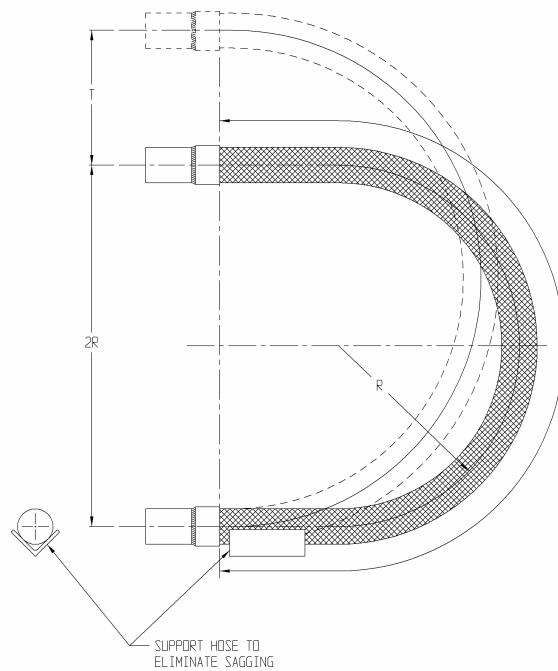

**Figure 3.6.5.2 Variable Radius Traveling Loop - Horizontal Travel**

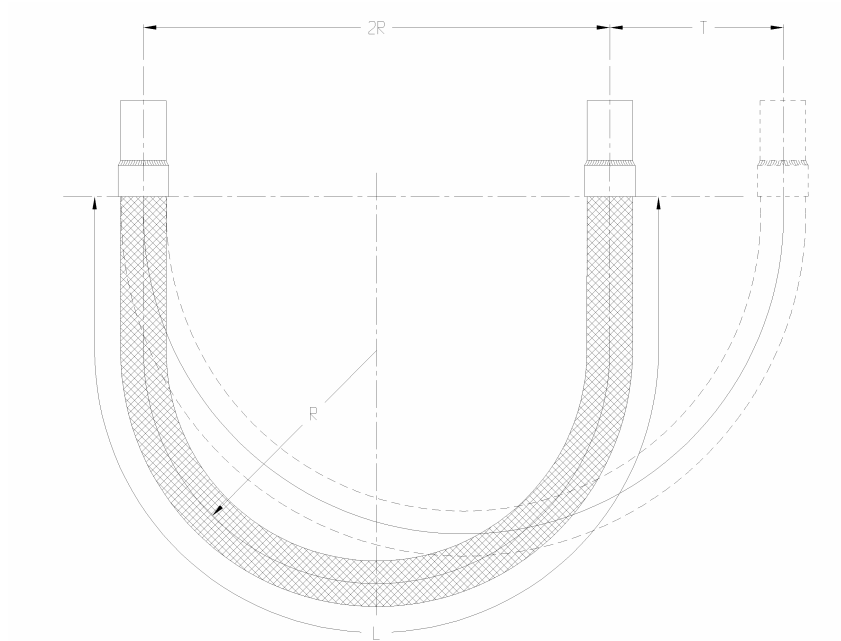

**Formula:**

$$L = 4(R) + 1.57(T)$$

Example: Travel (T) = 6.00+

2R = 40+

$$R = 40 \div 2 = 20+$$

$$L = 4(20+) + 1.57(6+) \quad L = 89.42+$$

$$OAL = 89.42++ 2(3.5+) = 96.42+$$

**Note:**

*For metal hose, R must be > or = MBR*

*For hose of Fluoropolymer, R must be > or = (MBR + S/2)*

### 3.6.6 Offset Motion

**Figure 3.6.6.1 Offset Motion**

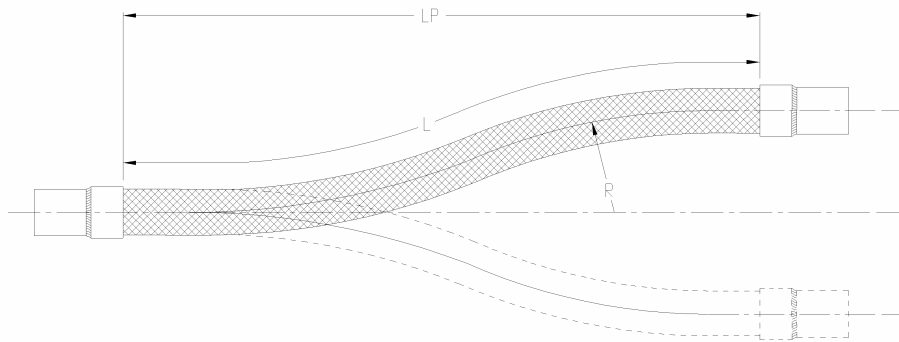

**Formula:**

$$L = (20R \times T)^{1/2}$$

For metal hose,  $R = MBR$

For hose of Fluoropolymer,  $R = (MBR) + S/2$

**Example:**

Travel ( $T$ ) = 3.00+Metal Hose

$$R = MBR = 14+$$

$$L = (20 \times 14 \times 3)^{1/2}$$

$$L = 28.98+$$

$$OAL = 28.98 + 2(3.5) = 35.98 + \text{Live Straight Length} \cdot L_p$$

$$L_p = (L^2 \cdot T)^{1/2}$$

$$L_p = (28.98^2 \cdot 3)^{1/2} = 3+2$$

$$L_p = 28.92+$$

$$\text{Overall straight installed length} = 28.82++ 2(3.5+) = 35.82+$$

**Note 1:**

When the offset motion occurs on both sides of the centerline, T = total travel = (T1+T2).

**Note 2:**

The offset distance  $\frac{\theta}{60}$  for constant flexing should never exceed 25% of the hoses stated minimum bend radius.

**3.6.7 Angular Motion**

**Figure 3.6.7.1 Angular Motion**

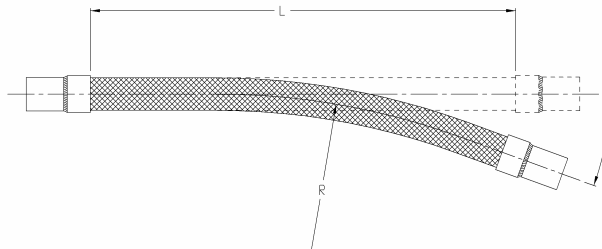

**Formula:**

$$L = 2(S) + (0/57.3)R$$

For hose of Fluoropolymer,  $R = (MBR + S/2)$  Example:  $\theta = 15$  Degrees

Metal Hose

$$R = MBR = 14+$$

$$L = 2(2.75)++ (15/57.3)14+L = 9.17+$$

$$OAL = 9.17++ 2(3.5+) = 16.17+$$

### 3.6.8 Vertical Loop with Movement in Two Directions

**Figure 3.6.8.1 Vertical Loop with Movement in Two Directions**

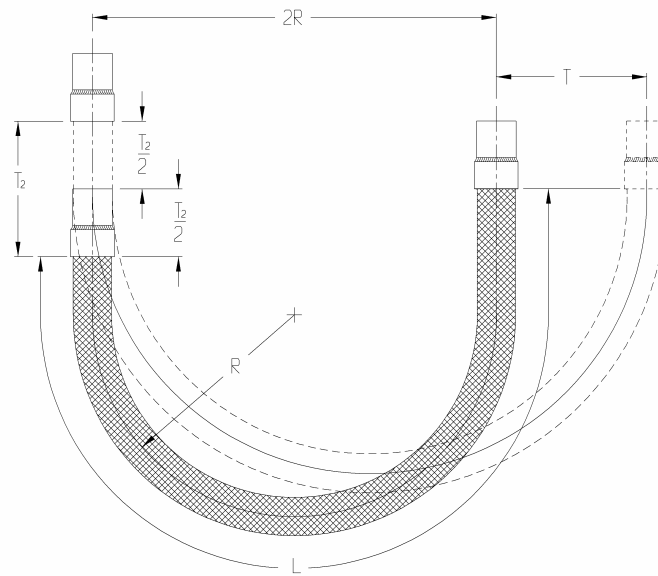

**Formula:**

$$L = 4(R) + 1.57 (Th) + (Tv)/2$$

$$L = 4(20") + 1.57(6") + (8")/2$$

$$L = 93.42"$$

$$OAL = 93.42" + 2(3.5") = 100.42"$$

**Note:**

For metal hose, R must be > or = MBR

For hose of Fluoropolymer, R must be > or = (MBR + S/2)

## 3.7 Assembly Methods

### 3.7.1 Purpose

The purpose of this section is to identify the most common types of assembly methods typically used to fabricate hose of Fluoropolymer assemblies.

### 3.7.2 Crimp Method

This method utilizes a machine that reduces the diameter of the fitting



collar or sleeve simultaneously along its length. The sizing die set usually consists of eight or ten fingers that are machined to a prescribed diameter. When placed in a series inside the throat of the crimper the reduced diameter can usually be adjusted with minor changes to the crimper. Crimp diameters are established by the hose manufacturer based on the successful completion of a series of qualification tests. When crimping the collar, the fitting remains stationary to the die set and is reduced through radial loading of the fingers. It is anticipated that the resulting outside surface of the collar or sleeve will exhibit multiple axial tool marks along its length. Care should be exercised to insure that the tooling does not leave deep marks that could be detrimental.

**Figure 3.7.2.1 Typical Crimped Collar**

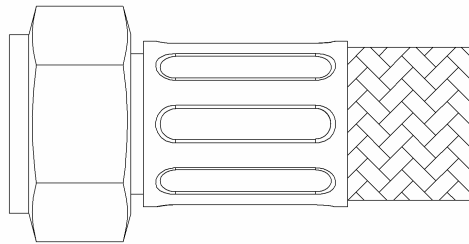

### 3.7.3 Swage Method

This method utilizes a machine that reduces the diameter of the fitting collar or sleeve progressively along its length. The sizing die set usually consists of two halves that are machined to a prescribed diameter and cannot be adjusted. Swage diameters are established by the hose manufacturer based on the successful completion of a series of qualification tests. When swaging the collar, the fitting is pushed progressively into the stationary die thus reducing the collar to a prescribed diameter. It is anticipated that the resulting outside surface of the collar or sleeve will exhibit two axial tool marks along its length.

**Figure 3.7.3.1 Typical Swaged Collar**

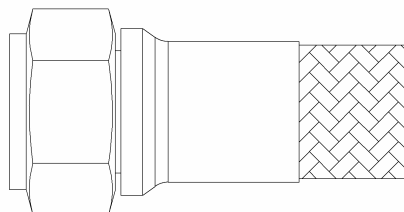

### 3.7.4 Flared Over Tubes of Fluoropolymer (Convolute & Smooth)

Typically, these types of hoses feature a heavy wall Fluoropolymer tube

(either smooth or a straightened portion of the convoluted hose) extending through the fitting. The liner is then formed over the fitting sealing surface to provide an area for sealing against a mating fitting. Metallic hose with a smooth inner liner of Fluoropolymer should meet the following criteria:

- A. Metal hose assembled to NAHAD Flexible Metal Hose Standard.
- B. Hose must incorporate a smooth transition from the convoluted I.D. to the Fitting with vent hole(s) burr free, no sharp edges, no metal chips, machined radii transition at the fitting sealing surface
- C. Hose features same flared over Fluoropolymer liner per Section 3.7.3.

Consult manufacturer for actual fabrication /assembly features. (This type assembly is usually a factory produced item due to the requirements of liner fit.)

## **Section 4 – Testing Procedures**

### **4.1 Purpose**

The following testing methods may or may not be required. Refer to the customer requirements and/or the appropriate assembly data sheets for recommended testing and documentation needed.

### **4.2 Hydrostatic Pressure Tests**

A pressure test is usually conducted applying the following criteria:

#### **Hose of Fluoropolymer -**

The hose assembly shall be subjected to a proof pressure test at a value defined by the contract or 1.5 times the maximum allowable working pressure, as determined by the following;

- Determine the MAWP of the hose
- Determine the MAWP of the fitting

The **LESSER** of these two values is the maximum allowable working pressure of the **assembly**.

#### ***Recommended Procedure***

A hydrostatic pressure test requires either a hand pump, a power driven

hydraulic pump, or an accumulator system. Connect the hose assembly to the test pump in a straight fashion, assuring a leak tight connection. It is extremely important that fittings, adapters, and any other mating components are rated for the pressure value of the test. It is recommended that the hose assembly be secured in an encapsulated tank that will withstand the pressure. The hose must be free to move slightly when pressure is applied.

An outlet valve should be applied to the hose end of the assembly that opposes the test pump end of the assembly. Unless otherwise specified by the customer, the test media should be water. Fill the hose with water while the outlet end is raised and the valve slightly opened to bleed all of the air from the system. Use the outlet valve to bleed all air remaining in the hose. When all the air has been expelled, close the outlet valve and lower the raised end.

*\*\*\*This is very important as a safety measure because expansion of air compressed in the hose, when suddenly released by bursting or other failure, might result in a serious accident. \*\*\**

Next for reference, mark a line behind the couplings which is at the end of the ferrule, clamp, band, etc. Then gradually raise the pressure to the desired pressure rating. Hold the pressure at for time dictated by hose type and conduct a visual inspection. As the pressure is raised, watch for visual indications of permanent deformation, leakage, and coupling slippage. If any of these are noted it is cause for rejection. After the test is complete, relieve the test pressure before disconnecting the hose assembly from the test equipment and drain the water from the hose. The hose may be flushed with alcohol if all of the water must be removed.

**WARNING\*\*WARNING\*\*WARNING\*\*WARNING\*\*WARNING**  
**Any failure during testing is likely to be of an explosive nature!**

Wherever particular skills are required, only specially trained persons should engage in those applications or testing procedures. Failure to do so may result in damage to the hose assembly or to other personal property and, more importantly, may also result in serious bodily injury.

Hoses must be properly cleaned prior to inspection and testing. This will prevent unexpected reactions between conveyants and the test media. Always wear safety glasses, gloves, and protective clothing to protect from leaks or high pressure spray. Also, use shields to protect people in the work area in the event of a hose burst, spray, or coupling blow-off.

It is recommended to never stand in front of, over, or behind the ends of a hose assembly during pressure testing. Also make sure that the hose is sufficiently shielded during pressure testing to stop a coupling in case of a coupling blow-off.

### **4.3 Pneumatic Pressure Test – Fluoropolymer hose**

When required by the customer, the hose assembly shall be subjected to a pneumatic pressure test at a value defined by the contract or the maximum allowable working pressure. Using a gaseous media, the assembly is immersed in a bath of water for a sufficient length of time to permit visual examination of all surface joints. Typical gas testing media are air and nitrogen. Minimum testing time should be one minute. Any evidence of leakage or permanent deformation is cause for rejection.

**Any failure during testing is likely to be of an explosive nature!**

When testing braided hose, care should be exercised to remove all entrapped air residing under the braid during the test so as not to confuse it with actual leakage. This may be accomplished using a water pick device while the assembly is immersed in the water bath.

### **4.4 Other Leakage Tests**

When leak rates are critical, consult the manufacturer for more sensitive testing methods. These may include but are not limited to the following: Mass Spectrometer Leak Testing, Pressure Decay, Vacuum Decay, Mass Flow, and Halogen Leak Test.

### **4.5 Electrical Continuity Test**

There are two types of electrical grounding paths for hoses: metallic and non-metallic. Hoses should be tested with a calibrated multi-meter from end fitting to end fitting to determine if the assembly is electrically continuous.

### **4.6 Electrical Resistance Test - UL330 Testing Method for an Assembly**

The maximum resistance for a hose assembly is determined by the standard that the assembly is made to conform, such as the requirement of 70,000 ohms/ft. per the UL 330 specification.

Hoses that are metallically grounded have a static wire, metal helical wire, or wire braid that is connected to the coupling on each end of the hose. Per the UL 330 specification, the electrical resistance of a metallic grounded hose can be measured with a standard low-voltage ohmmeter. Hoses which have grounding paths that have resistance greater than 1000 ohms require electrical continuity testing to be done with an ohmmeter that has an internal resistance of 100,000 ohms +/- 10 percent, with an open circuit potential of 500 volts, D.C.

Hoses that are non-metallically grounded utilize a conductive material to achieve electrical continuity. These hoses require electrical continuity testing to be

completed with an ohmmeter that has an internal resistance of 100,000 ohms +/- 10 percent with an open circuit potential of 500 volts, D.C.

The electrical resistance of the hose is measured from coupling connection to the other end coupling connection while pressurized with air, nitrogen, or kerosene at 75 psig. During the electrical continuity testing, if there is a swivel coupling present, the swivel must be rotated 360 degrees while the ohmmeter leads are attached and the hose is under 75 psig pressure. The highest reading during the test is considered to be the electrical resistance of the hose assembly.

#### **4.7 Visual Inspection**

All sample assemblies should be visually inspected for substandard quality conditions in the hose or couplings. Each assembly should be visually inspected for kinks, loose covers, bulges or ballooning, soft spots, cuts, broken wires, or any obvious defect in the hose. The fittings and attachments should be inspected for any type of visible defects that may affect the performance of the assembly.

Visual inspection checkpoints should include but are not limited to the following:

- A. Hose Identification - Size and type must correspond to the fabrication order (work order)
- B. Coupling Identification - Coupling size, type, and product number must correspond to information on the fabrication order (work order) and specifications. Identified with date code, part number, etc. when required.
- C. Inspection Items .
  - Bulge behind the coupling
  - Cocked couplings
  - Cracked couplings
  - Exposed reinforcement
  - Freedom of swivels
  - General appearance of the assembly
  - Hose cover pricked if required
  - Internal contaminants
  - Protective caps or plugs
  - Restriction in the tube
  - Rusted couplings

#### **4.8 Calibrations**

Inspection and testing equipment used in the production or testing of coupled hose assemblies should be calibrated at prescribed intervals according to written

procedures. All gauging equipment shall be calibrated regularly by means traceable to NIST (National Institute of Standards and Technology). The tag giving date of last calibration, next calibration due date and signature of the inspector shall be attached to the gauge and a record filed for future reference.

## **4.9 Test Documentation**

If required by the customer, a test certificate may be issued to provide written confirmation that the assembly has been tested, and conforms to certain performance criteria. If a test certificate is not supplied, test results should be maintained and kept on file for five years.

Each test certificate should bear a unique number for traceability.

Test certificates may include any or all of the following information as a minimum:

- A. Test Certificate Number
- B. Customers Name and Purchase Order Number
- C. Suppliers Name and Job Number
- D. Hose Serial Number(s)
- E. Hose details including length, type of hose and diameter
- F. End fitting details with types of ferrules and seals used
- G. Test Date
- H. Test Pressure
- I. Electrical Continuity Conformance
- J. Suppliers Authorization Signature

## **4.10 Other Documentation**

Other types of documentation may be requested by the customer. All certificates and reports required should accompany the shipment, unless otherwise specified.

### **4.10.1 Certificate of Conformance**

When required, a Certificate of Conformance (C of C) may be supplied with the order, confirming in the form of a text, and without expressed mention of the test results, that the product being supplied meets the requirements of the customers purchase order, as agreed upon order acceptance. The C of C should have the following information, if applicable:

a.	Customer's Name
b.	Customer's Address
c.	Customer's Purchase Order
d.	Customer's Contract Number
e.	Customer's Specification Number
f.	Customer's Drawing Number
g.	Supplier's Name
h.	Supplier's Address
i.	Supplier's Order Number
j.	Supplier's Drawing Number
k.	Quantity
l.	Description
m.	Additional Information
n.	Supplier's Authorized Signature
o.	Date

#### 4.10.2 Test Report

A request for a C of C may require that actual test results be included.

#### 4.10.3 Certified Material Test Reports

When required, a Certified Material Test Report (CMTR) shall be supplied showing the materials meet the requirements of the customer's purchase order. These may be supplied as copies of the raw material CMTR's provided by the materials supplier or on the manufacturer's form providing certified test results.

#### 4.10.4 Third Party Certification

When required by the customer, an authorized inspection party shall inspect and certify that the product being supplied meets the requirements of the customer's purchase order as agreed upon order acceptance. Upon request, copies of these certifications shall be supplied.

## Section 5 – Quality Plan

### 5.1 Purpose

The purpose of this section is to outline a quality plan for fabricating hose assemblies. The assurance of an acceptable hose assembly reaching the customer depends upon the quality of the components and the workmanship of the fabricator.

An effective quality control plan is based on statistical sampling principles.

Responsibility for supervising the quality plan must be designated. Corrective action procedures must be formalized to deal with nonconformance.

## 5.2 Sampling Plan

An effective sampling plan is based on the statistical history of a design that demonstrates quality performance and sets confidence levels.

Sampling is performed in an effort to statistically evaluate a product or process against tolerances that are considered acceptable as determined by national standards, customer requirements, etc. This monitoring of product or process with an adequate sampling plan is done in an effort to provide 100% acceptable product to the customer. In an ideal world, if inspection capability is 100% effective, then the only way to assure 100% acceptable product is to inspect everything 100%. Due to practical considerations of time and resources (both manpower and financial), 100% inspection will probably not occur as a standard method of operation.

There are many areas or processes that may be sampled. These may vary from operation to operation, but there are some constants that should probably apply no matter what the operation.

- A. Inspection of incoming material . You cannot guarantee the quality of the outgoing product, if the quality of incoming materials has not been verified.
- B. In process inspection . This may be as simple as inspection of the first assembly produced. Or it may be quite complicated, such as doing a complete dimensional audit on so many pieces per production run and plotting these results on Statistical Process Control (SPC) charts in order to track trends and potential problems.
- C. Final Inspection . This may be relatively simple, such as verifying piece counts before shipping to the customer, or as complicated as checking specific criteria to ensure compliance with the customer's requirements. Regardless of what is being sampled, inspection characteristics, the corresponding documentation and the personnel responsible for carrying for inspecting these characteristics, must be defined.

When establishing the frequency of sampling, there are many factors that need to be considered. These include but are not limited to:

- 1. Complexity of process
- 2. Application
- 3. Liability
- 4. Stability of procedure



## 5. Cost

If a process is very stable as indicated by past performance, the frequency of sampling can be decreased. There is no specific sampling plan that can be considered best suited to all applications.

### 5.3 Material Receiving Inspection

#### 5.3.1 Couplings

Upon receipt of a shipment of couplings, the assembly fabricator should perform, at minimum, the following inspection steps:

1. Compare the couplings received with the purchase order by making sure part numbers agree between order and packing slip.
2. Check the count between packing slip and actual quantity received.
3. Check the product in the package to make sure it agrees with the part number on the package. Supplier catalogs are a good reference.
4. When possible, leave the couplings in the original container with the original date code. If a coupling problem arises later, all the couplings of that size and date code can be separated out for 100% inspection purposes.
5. At least one coupling from every box should be inspected for dimensions, defective plating, concentricity, snap rings attached to the swivels, any damage from shipping.
6. A certificate of conformance may be requested for all fittings.

#### 5.3.2 Hose

Upon the receipt of a shipment of hose, the assembly fabricator should perform, at a minimum, the following inspection steps:

1. Check product numbers on the packing list with numbers on the packages of the actual merchandise.
2. Check total footage against the packing slip, making sure they agree.
3. Check the product, making sure it agrees with the label on the packaging.
4. Check the hose inside diameter, outside diameter and reinforcement,

and verify against the manufacturer's product information.

5. All hose should be visibly inspected for damage due to shipping, kinks, loose cover, bulges, ballooning, cuts, crush, and tears. A certificate of conformance may be requested with the hose.

## **5.4 Storage (Labeling, Environment, Time)**

Proper storage will maximize hose shelf life. All hose should be stored in such a manner to protect them from degrading factors such as humidity, temperature extremes, ozone, sunlight, direct light from fluorescent or mercury lamps, oils, solvents, corrosive liquids, insects, rodents, and any other degrading atmosphere.

Care should be taken when stacking hose, as its weight can crush hose at the bottom of the stack. The stack could also become unstable, creating a safety hazard.

### **Note:**

The ideal storage temperature for rubber hose is +50°F to +70°F with the maximum of +100°F. Care should be taken to keep rubber hoses from being stored next to heat sources. Rubber hose should not be stored near electrical equipment that generates ozone. Exposure to high concentrations of ozone will cause damage to the hose.

Store components in a cool, dry area. If stored below freezing, pre-warming may be required prior to handling, testing and placing into service.

Components should be stored in original date-coded containers. Steps should be made to rotate inventory on a first-in, first-out basis, to insure that the products are exposed to the shortest shelf time possible

## **Section 6 – Assembly Identification, Cleaning and Packaging**

### **6.1 Purpose**

This section is intended to establish methods and content of applying hose assembly identification markings and identify minimum cleaning and packaging requirements.

### **6.2 Hose Assembly Markings**

#### **6.2.1 Method of Marking**

The marking of hose assemblies may be achieved in many ways:

- A. Information pre-stamped in legible characters on metal tag or band affixed to the assembly by approved durable method.
- B. Information in legible characters permanently marked directly onto the ferrule or fitting.
- C. Printed heat shrink

\*Excluded from this document are acceptable marking methods for Chlorine hose (refer to Pamphlet #6) as well as high purity applications.

## **6.3 Cleaning**

Each assembly shall be supplied to the customer free of water, debris, metal shavings, dirt or any foreign material that may cause problems to the application. Air may be blown through the assembly to remove loose particles. Some customers have stringent cleanliness requirements that may require flushing the assembly. End connection openings should be sealed or capped to assure that cleanliness is maintained.

Consult the customer information for specific cleaning requirements.

## **6.4 Packaging**

Hose assemblies shall be packaged in such a manner to insure that external abuse during shipping and handling does not damage the hose or fittings.

Hose shall be packed in a clean and dry state.

Containers, boxes, banding and pallets shall be of sufficient size and strength to withstand handling and transit without failure. When packaged, hose assemblies should not be coiled tighter than the specified minimum bend radius. Check customer information for any specific labeling.

# **Section 7 – Installation and Handling**

## **7.1 Purpose**

The purpose of this section is to increase awareness on the proper installation and handling of hose assemblies, and to alert fabricators, installers and end-users to the safety hazards in the field.

Hoses and hose assemblies are used interchangeably in this document. Hoses are used to convey liquids, gases and other media. Hose constructions are available in a variety of materials and styles depending on the intended application.

## **7.2 General**

All hose has a finite life and there are a number of factors, which will reduce its life. The design and use of systems, which contain hoses, require consideration of factors related to specific application requirements.

## **7.3 Safety Considerations**

Below are some potential conditions that can lead to personal injury and property damage. This list is not inclusive. Consider reasonable and feasible means, including those described in this section to reduce the risk of injuries or property damage.

Employers with hose assemblies in fluid systems are encouraged to provide training, including the information in this document, for maintenance personnel and other employees working with and around hoses under pressure.

### **7.3.1 Media Permeation**

Hoses should always be used in well-ventilated areas. Certain media will permeate through hoses that can displace breathable air in confined spaces. Consult the manufacturer if in question.

### **7.3.2 Fluid Injections**

Fine streams of pressurized fluid can penetrate skin and enter a human body. Fluid injection wounds may cause severe tissue damage and loss of limb. Consider the use of guards and shields to reduce the risk of fluid injections.

If a fluid injection occurs, contact a doctor or medical facility at once. Do not delay or treat as a simple cut. Fluid injections are serious injuries and prompt medical treatment is essential. Be sure the doctor knows how to treat this type of injury.

Avoid all contact with escaping fluids. Treat all leaks as though they are pressurized and hot or caustic enough to burn skin.

### **7.3.3 Whipping Hose**

If a pressurized hose or hose fitting comes apart, the loose hose end can flail or whip with great force, and fittings can be thrown off a high speed. This is particularly true in compressible gas or fluid systems. If the risk of hose whipping exists, consider the use of guards and restraints.

### **7.3.4 Fire and Explosions from Conveyed Fluids**

All hydraulic fluids, including many designated as "Fire Resistant", are flammable (will burn) when exposed to the proper conditions.

Fluids under pressure which escape from system containment, may develop a mist or fine spray that can explode upon contact with a source of ignition (e.g.; open flames, sparks, hot manifolds.) These explosions can be very severe and could cause extensive property damage, serious injury or death. Care should be taken to eliminate all possible ignition sources from contact with escaping fluids, fluid spray or mist, resulting from hydraulic system failures. Select and route hoses to minimize the risk of combustion.

### **7.3.5 Fire and Explosions from Static-Electric Discharge**

Fluid passing through hose can generate static electricity, resulting in static-electric discharge. This may create sparks that can ignite system fluids or gases in the surrounding atmosphere. Use hose rated for static conductivity or a proper grounding device. Consult manufacturer for proper hose and coupling selection.

### **7.3.6 Burns from Conveyed Fluids**

Fluid media conveyed in certain applications may reach temperatures that can burn human skin. If there is risk of burns from escaping fluid, consider guards and shields to prevent injury, particularly in areas normally occupied by operators

### **7.3.7 Electrical Shock**

Electrocution could occur when a hose assembly conducts electricity to a person. Most hoses are conductive. Many have metal fittings. Even nonconductive hoses can be conduits for electricity if they carry conductive fluids.

Certain applications require hose to be nonconductive to prevent electrical current flow. Other applications require the hose to be sufficiently conductive to drain off static electricity. Hose and fittings must be chosen with these needs in mind. Consult manufacturer with any questions.

**Note:**

Always use proper grounding to minimize the risk of electrical discharge.

**Note:**

Be aware of routing hydraulic hose near an electrical source. When this cannot be avoided, nonconductive hoses should be considered. SAE J517-100R7 and 100R8 hoses with orange covers marked **Nonconductive** are available for applications requiring nonconductive hose.

### **7.3.8 Fluid Controlled Mechanisms**

Mechanisms controlled by fluids in hoses can become hazardous if a hose fails. For example, when a hose bursts, objects supported by the fluid pressure may fall. If mechanisms are controlled by fluid power, use hose with design characteristics sufficient to minimize the potential risks of injury or property damage.

### **7.3.9 Air and Gaseous Applications**

Consult manufacturer for proper hose and coupling selection. The covers of hose assemblies that are to be used to convey air and other gaseous materials must be pin perforated.

**CAUTION:** Exercise care not to perforate beyond the cover. These perforations allow gas that has permeated through the inner tube of the hose to escape into the atmosphere. This prevents gases from accumulating and blistering the hose.

## **7.4 Hose Installation and Replacement**

The following practices shall be used when installing hose assemblies in new systems or replacing hose assemblies in existing systems.

### **7.4.1 Pre-Installation Inspection**

Before installing hose assemblies, the following shall be examined:

- A. Hose length and routing for compliance with original design.
- B. Correct style, size, length, and visible non-conformity of assembly.
- C. Fitting seats for burrs, nicks or other damage.
- D. Kinked, crushed, flattened, or twisted hose.

### **7.4.2 Handling During Installation**

Handle hose with care during installation; bending beyond the minimum bend radius will reduce hose life. Sharp bends at the hose to fitting

junction should be avoided. Bends at hose to fitting junction should start at a minimum of 2 times the ID of the hose.

### **7.4.3 Torque**

Hose assemblies shall not be installed or operated in a twisted or torqued condition. Swivel fittings or a lay line may be used to aid in torque-free installation.

### **7.4.4 Hose Routing**

When planning the hose routing use the following practices for optimum performance and more consistent and predictable service life.

Routing at less than minimum bend radius, will reduce the service life of the hose. Use the static or dynamic minimum bend radius according to service conditions. Sharp bends at the hose to fitting junction should be avoided

Hose assemblies subject to movement while operating should be installed in such a way that flexing occurs in the same plane.

### **7.4.5 Securement and Protection**

Necessary restraints and protective devices shall be installed. Such devices shall not create additional stress or wear points.

### **7.4.6 System Checkouts**

In some liquid systems, it may be necessary to eliminate all entrapped air after completing the installation. Follow manufacturer's instructions to test the system for possible malfunctions and leaks.

To avoid injury during system checkouts, do not touch any part of the hose assembly when checking for leaks and stay out of potentially hazardous areas while testing hose systems. (See Safety Considerations.)

## **7.5 Maintenance Inspection**

A hose and fitting maintenance program can reduce equipment down time and maintain peak operating performance.

### **7.5.1 Inspection Frequency**

The nature and severity of the application, past history and manufacturer's recommendations shall be evaluated to determine the frequency of the visual inspections and functional tests. However, in the absence of this

information, we recommend a visual inspection be conducted before each shift or at least once a day.

To avoid injury during system checkouts, do not touch any part of the hose assembly when checking for leaks and stay out of potentially hazardous areas while testing hose systems. (See Safety Considerations.)

### **7.5.2 Visual Inspections**

The hose and fittings shall be visually inspected for:

- A. Leaks at the hose fittings or in the hose.
- B. Damaged, abraded, or corroded braid; or broken braid wires.
- C. Cracked, damaged, or badly corroded fittings.
- D. Other signs of significant deterioration.

If any of these conditions exist, the hose assemblies shall be evaluated for replacement.

### **7.5.3 Visual Inspections for All Other Components**

Hose and fittings shall be visually inspected for:

- A. Leaking ports.
- B. Damaged or missing hose clamps, guards, or shields.
- C. Excessive dirt and debris around hose.
- D. System fluid.
- E. Level, type, contamination, condition, and air entrapment or blockage.

If any of these conditions are found, appropriate action shall be taken.

### **7.5.4 Functional Tests**

Functional tests shall be conducted to determine if systems with hose are leak-free and operating properly. Such tests should be conducted in accordance with the manufacturers recommendations.



## APPENDIX A – Pressure Conversion Chart

psi	Atms	inches H <sub>2</sub> O	inches Hg	mm Hg (Torr)	mbar	Bar	Pa (N/m <sup>2</sup> )	kPa	MPa
1	0.0681	27.71	2.036	51.715	68.95	0.0689	6895	6.895	0.0069
14.7	1	407.2	29.92	760	1013	1.013	101,325	101.3	0.1013
0.0361	0.00246	1	0.0735	1.866	2.488	0.00249	248.8	0.249	0.00025
0.4912	0.03342	13.61	1	25.4	33.86	0.0339	3386	3.386	0.00339
0.01934	0.001316	0.536	0.0394	1	1.333	0.001333	133.3	0.1333	0.000133
0.0145	0.000987	0.4012	0.0295	0.75	1	0.001	100	0.1	0.0001
14.504	0.987	401.9	29.53	750	1000	1	100,000	100	0.1
0.000145	0.00001	0.00402	0.000295	0.0075	0.01	0.00001	1	0.001	0.000001
0.14504	0.00987	401.9	0.295	7.50	10	0.01	1000	1	0.001
145.04	9.869	401.9	295.3	7500	10,000	10	1,000,000	1000	1

To use this chart:

1. Locate the column with the units you want to convert from.
2. Move DOWN that column until you locate the **1**.
3. Move HORIZONTALLY to the column with the units you want to convert to.
4. MULTIPLY the number in the box by the amount you are changing from to get the converted value.

### Length

$$1 \text{ cm} = 0.3937 \text{ in} = 10 \text{ mm} = 0.01 \text{ m}$$

$$1 \text{ m} = 3.2808 \text{ ft} = 1000 \text{ mm} = 100 \text{ cm}$$

$$1 \text{ in} = 2.540 \text{ cm} = 25.40 \text{ mm}$$

$$1 \text{ ft} = 30.48 \text{ cm} = 0.3048 \text{ m}$$

### Volume

$$1 \text{ L} = 0.0353 \text{ ft}^3$$

$$1 \text{ L} = 0.2642 \text{ gal}$$

$$1 \text{ L} = 61.025 \text{ in}^3$$

$$1 \text{ L} = 0.001 \text{ m}^3$$

$$1 \text{ ft}^3 = 28.3286 \text{ L}$$

$$1 \text{ Gal} = 0.1336 \text{ ft}^3$$

### Pressure

$$1 \text{ psi} = 0.0681 \text{ atm}$$

$$1 \text{ psi} = 27.71 \text{ in H}_2\text{O}$$

$$1 \text{ psi} = 703.8 \text{ mm H}_2\text{O}$$

$$1 \text{ psi} = 2.036 \text{ in Hg}$$

$$1 \text{ psi} = 51.715 \text{ mm Hg (torr)}$$

$$1 \text{ psi} = 68.95 \text{ mbar}$$

$$1 \text{ psi} = 0.0689 \text{ bar}$$

$$1 \text{ psi} = 6895 \text{ Pa (n/m}^2\text{)}$$

$$1 \text{ psi} = 6.895 \text{ kPa}$$

$$1 \text{ psi} = 0.0069 \text{ MPa}$$

## **APPENDIX B – References**

### **ANSI**

American National Standards Institute  
Attn: Customer Service  
25 West 43<sup>rd</sup> Street  
New York, NY 10036  
Phone: (212) 642-4900  
Fax: (212) 398-0023  
E-mail: [info@ansi.org](mailto:info@ansi.org)  
Internet: <http://www.ansi.org>

### **ASME**

American Society for Mechanical Engineers  
22 Law Drive  
Box 2900  
Fairfield, NJ 07007-2900  
Phone: (800) 843-2763; (973) 882-1167  
Fax: (973) 882-1717; (973) 882-5155  
E-mail: [infocentral@asme.org](mailto:infocentral@asme.org)  
Internet: <http://www.asme.org>

### **ASQ**

American Society for Quality  
600 North Plankinton Avenue  
Milwaukee, WI 53203  
Phone: (800) 248-1946  
Fax: (414) 272-1734  
E-mail: [help@asq.org](mailto:help@asq.org)  
Internet: <http://www.asq.org>

### **ASTM International**

100 Barr Harbor Drive  
West Conshohocken, PA 19428-2959  
Phone: (610) 832-9585  
Fax: (610) 832-9555  
E-mail: [service@astm.org](mailto:service@astm.org)  
Internet: <http://www.astm.org>

### **Document Center, Inc.**

111 Industrial Road, Suite 9  
Belmont, CA 94002  
Phone: (650) 591-7600  
Fax: (650) 591-7617  
E-mail: [mailto:info@document-center.com](mailto:mailto:info@document-center.com)  
Internet: <http://www.document-center.com/>

**Global Engineering Documents**

15 Inverness Way East  
Englewood, CO 80112  
Phone: (800) 854-7179; (303) 397-7956  
Fax: (303) 397-2740  
Email: [global@ihs.com](mailto:global@ihs.com)  
Internet: <http://www.ihs.com>

**Government Printing Office**

732 North Capitol St. NW  
Washington, DC 20401  
Phone: (202) 512-0000  
Email: [webteam@gpo.gov](mailto:webteam@gpo.gov)  
Internet: <http://www.gpo.gov>

**ISO**

International Organization for Standardization (ISO)  
1, rue de Varembé, Case postale 56  
CH-1211 Geneva 20, Switzerland  
Phone: +41 22 749 01 11  
Fax: +41 22 733 34 30  
Internet: <http://www.iso.org>

**NAHAD**

The Association for Hose and Accessories Distribution  
105 Eastern Ave. Suite 104  
Annapolis, MD 21403-3300  
Phone: (410) 263-1014  
Fax: (410) 263-1659  
E-mail: [nahad@nahad.org](mailto:nahad@nahad.org)  
Internet: <http://www.nahad.org>

**RMA**

Rubber Manufacturers Association c/o The Mail Room  
P.O. Box 3147  
Medina, OH 44258-3147  
Phone: (800) 325-5095; (330) 723-2978  
Fax: (330) 725-0576  
E-mail: [info@rma.org](mailto:info@rma.org)  
Internet: <http://www.rma.org>

**SAE**

Society of Automotive Engineers  
400 Commonwealth Drive  
Warrendale, PA 15096-0001  
Phone: (877) 606-7323;  
Fax: (724) 776-0790  
Email: [customerservice@sae.org](mailto:customerservice@sae.org)  
Internet: <http://www.sae.org>

**UL**

Underwriters Laboratory  
333 Pfingsten Road  
Northbrook, IL 60062-2096 USA  
Telephone: (847) 272-8800  
Fax: (847) 272-8129

## APPENDIX C – Hose Ends

### 37° Flare (JIC)

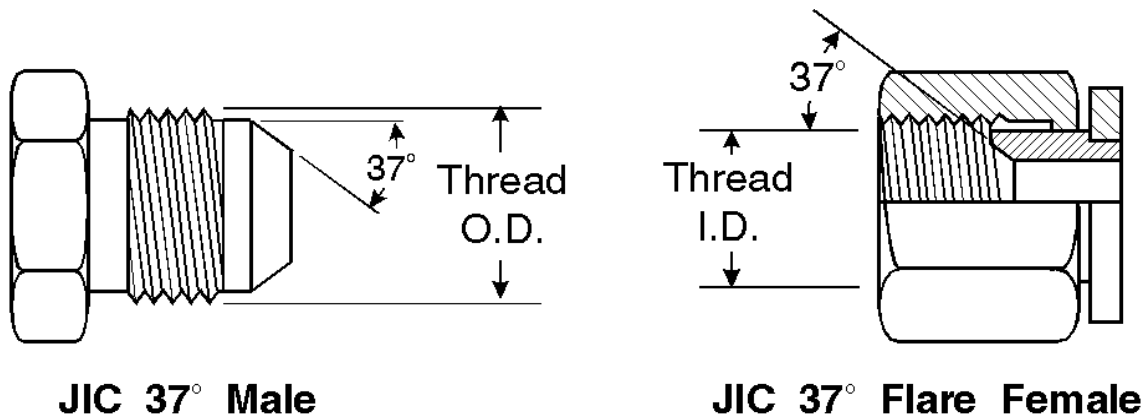

The Society of Automotive Engineers (SAE) specifies a 37° angle flare or seat be used with high pressure hydraulic tubing. These are commonly called JIC couplings.

The JIC 37° flare male will mate with a JIC female only. The JIC male has straight threads and a 37° flare seat. The JIC female has straight threads and a s/b 37° flare set. The seal is made on the 37° flare seat.

Some sizes have the same threads as the SAE 45° flare. Carefully measure the seat angle to differentiate.

\*Note: Some couplings may have dual machined seats (both 37° and 45° seats).

Dash Size	Nominal Size (in.)	Thread Size	Female Thread I.D. (in.)	Male Thread O.D. (in.)
-2	1/8	5/16-24	17/64	5/16
-3	3/16	3/8-24	21/64	3/8
-4	1/4	7/16-20	25/64	7/16
-5	5/16	1/2-20	29/64	1/2
-6	3/8	9/16-18	1/2	9/16
-8	1/2	3/4-16	11/16	3/4
-10	5/8	7/8-14	13/16	7/8
-12	3/4	1-1/16-12	31/32	1-1/16
-14	7/8	1-3/16-12	1-7/64	1-3/16
-16	1	1-5/16-12	1-15/64	1-5/16
-20	1-1/4	1-5/8-12	1-35/64	1-5/8
-24	1-1/2	1-7/8-12	1-51/64	1-7/8
-32	2	2-1/8-12	2-27/64	2-1/2

**SAE (45° Flare)**

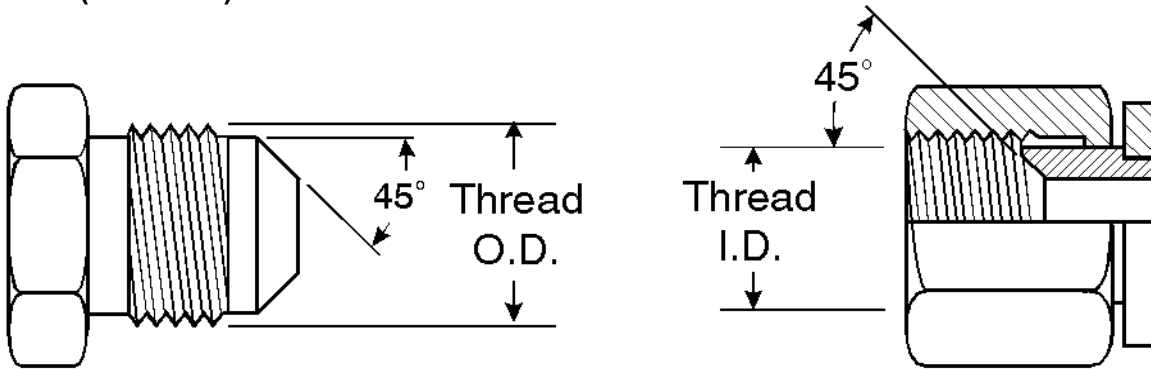

**SAE 45° Flare Male**

**SAE 45° Flare Swivel Female**

A term usually applied to fittings having a 45° angle flare or seat. Soft copper tubing is generally used in such applications as it is easily flared to the 45° angle. These are for low pressure applications such as for fuel lines and refrigerant lines.

The SAE 45° flare male will mate with an SAE 45° flare female only. The SAE male has straight threads and a 45° flare seat. The SAE female has straight threads and a 45° flare seat. The seal is made on the 45° flare seat. Some sizes have the same threads as the SAE 37° flare. Carefully measure the seat angle to differentiate.

\*Note: Some couplings may have dual machined seats (both 37° and 45° seats).

Dash Size	Nominal Size (in.)	Thread Size	Female Thread I.D. (in.)	Male Thread O.D. (in.)
-2	1/8	5/16-24	17/64	5/16
-3	3/16	3/8-24	21/64	3/8
-4	1/4	7/16-20	25/64	7/16
-5	5/16	1/2-20	29/64	1/2
-6	3/8	5/8-18	9/16	5/8
-7	7/16	11/16-6	5/8	11/16
-8	1/2	3/4-16	11/16	3/4
-10	5/8	7/8-14	13/16	7/8
-12	3/4	1-1/16-12	63/64	1-1/16
-14	7/8	1-1/4-12	1-11/64	1-1/4
-16	1	1-3/8-12	1-19/64	1-3/8

## "O" Ring Boss

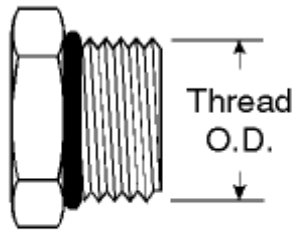

**"O" Ring Boss Male**

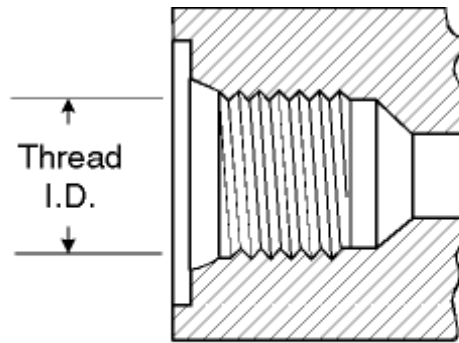

**"O" Ring Boss Female Port**

The O-ring boss male will mate with an O-ring boss female only. The female is generally found on ports. The male has straight threads and an O-ring. The female has straight threads and a sealing face. The seal is made at the O-ring on the male and the sealing face on the female.

Dash Size	Nominal Size (in.)	Thread Size	Female Thread I.D. (in.)	Male Thread O.D. (in.)
-2	3/16	3/8-24	21/64	3/8
-4	1/4	7/16-20	25/64	7/16
-5	5/16	1/2-20	29/64	1/2
-6	3/8	9/16-18	1/2	9/16
-8	1/2	3/4-16	11/16	3/4
-10	5/8	7/8-14	13/16	7/8
-12	3/4	1-1/16-12	31/32	1-1/16
-14	7/8	1-3/16-12	1-7/64	1-3/16
-16	1	1-5/16-12	1-15/64	1-5/16
-20	1-1/4	1-5/8-12	1-35/64	1-5/8
-24	1-1/2	1-7/8-12	1-51/64	1-7/8
-32	2	2-1/2-12	2-27/64	2-1/2

### "O" Ring Flange -- SAE J518

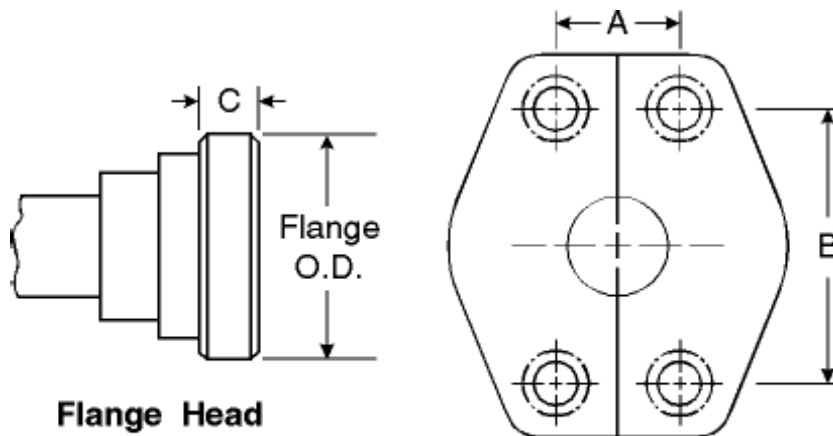

### 4-Bolt Split Flange Bolt Hose Dimensions

The SAE Code 61 and Code 62 4-Bolt Split Flange is used worldwide, usually as a connection on pumps and motors. There are three exceptions.

1. The -10 size, which is common outside of North America, is not an SAE Standard size.
2. Caterpillar flanges, which are the same flange O.D. as SAE Code 62, have a thicker flange head ( $\frac{1}{16}$ " dimension in Table).
3. Poclain flanges, which are completely different from SAE flanges.

Nominal Flange Size	Code 61 Flange O.D.	A	B	C	Code 62 Flange O.D.	A	B	C	Caterpillar Flange O.D.	A	B	C
1/2	1.188	.688	1.500	.265	1.250	.718	1.574	.305	-	-	-	-
5/8	1.338	.265	-	.265	-	-	-	-	-	-	-	-
3/4	1.500	.875	1.875	.265	1.625	.937	2.000	.345	1.625	.938	2.000	.560
1	1.750	1.031	2.062	.315	1.875	1.093	2.250	.375	1.875	1.094	2.250	.560
1-1/4	2.000	1.188	2.312	.315	2.125	1.250	2.625	.405	2.125	1.250	2.625	.560
1-1/2	2.375	1.406	2.750	.315	2.500	1.437	3.125	.495	2.500	1.438	3.125	.560
2	2.812	1.688	3.062	.375	3.125	1.750	3.812	.495	3.125	1.750	3.812	.560
2-1/2	3.312	2.000	3.500	.375	-	-	-	-	-	-	-	-
3	4.000	2.438	4.188	.375	-	-	-	-	-	-	-	-
3-1/2	4.500	2.750	4.750	.442	-	-	-	-	-	-	-	-
4	5.000	3.062	5.125	.442	-	-	-	-	-	-	-	-
5	6.000	3.625	6.000	.442	-	-	-	-	-	-	-	-



**"O" Ring Face Seal SAE J1453**

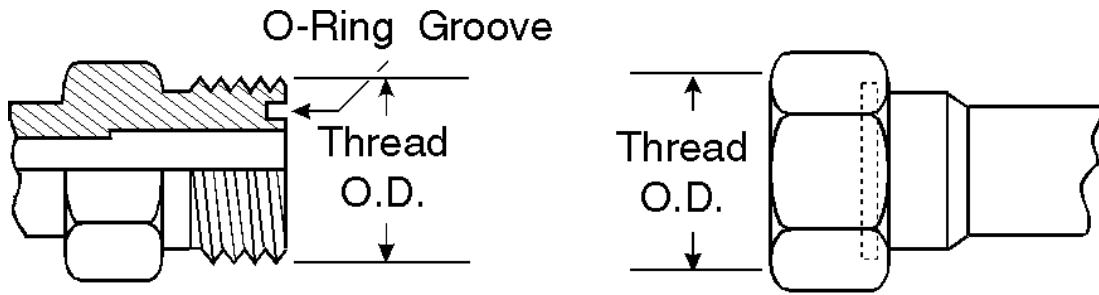

**O-Ring Face Seal  
Solid Male**

**O-Ring Face Seal  
Swivel Female**

A seal is made when the O-ring in the male contacts the flat face on the female. Couplings are intended for hydraulic systems where elastomeric seals are acceptable to overcome leakage and leak resistance is crucial. The solid male O-ring face seal fitting will mate with a swivel female O-ring face seal fitting only. An O-ring rests in the O-ring groove in the male.

Dash Size	Nominal Size (in.)	Thread Size	Female Thread I.D. (in.)	Male Thread O.D. (in.)
-4	1/4	9/16-18	9/16	1/2
-6	3/8	11/16-16	11/16	5/8
-8	1/2	13/16-16	13/16	3/4
-10	5/8	1-14	1	15/16
-12	3/4	1-3/16-12	1-3/16	1-1/8
-16	1	1-7/16-12	1-7/16	1-11/32
-20	1-1/4	1-11/16-12	1-11/16	1-19/32
-24	1-1/2	2-12	2	1-29/32

### Pipe Threads

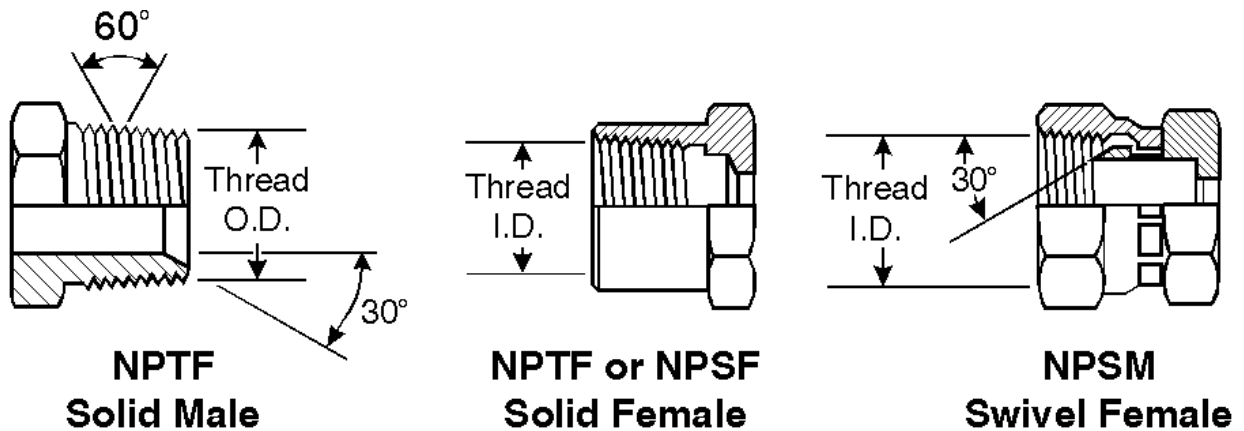

NPTF -- This is a dryseal thread; the National pipe tapered thread for fuels. This is used for both male and female ends. The NPTF male will mate with the NPTF, NPSF, or NPSM female. The NPTF male has tapered threads and a 30° inverted seat. The NPTF female has tapered threads and no seat. The seal takes place by deformation of the threads. The NPSM female has straight threads and a 30° inverted seat. The seal takes place on the 30° seat. The NPTF connector is similar to, but not interchangeable with, the BSPT connector. The thread pitch is different in most sizes. Also, the thread angle is 60° instead of the 55° angle found on BSPT threads.

NPSF -- The National pipe straight thread for fuels. This is sometimes used for female ends and properly mates with the NPTF male end. However, the SAE recommends the NPTF thread in preference to the NPSF for female ends.

Dash Size	Nominal Size (in.)	Thread Size	Female Thread I.D. (in.)	Male Thread O.D. (in.)
-2	1/8	27	23/64	13/32
-4	1/4	18	15/32	35/64
-6	3/8	18	19/32	43/64
-8	1/2	14	3/4	27/32
-12	3/4	14	61/64	1-1/16
-16	1	11-1/2	1-13/64	1-13/64
-20	1-1/4	11-1/2	1-17/32	1-17/32
-24	1-1/2	11-1/2	1-25/32	1-25/32
-32	2	11-1/2	2-1/4	2-3/8

## JIC Fitting



1/4" through 2" (6.4 mm through 50.8 mm) Diameter  
Carbon Steel  
Stainless Steel  
Pressure rating  
Temperature vary with size and material selected

## Slip-on Flange

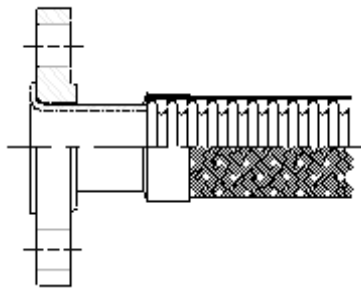

1/4" through 4" (6.4 mm through 101.6 mm) Diameter  
ASTM-A-105 Carbon  
ASTM-A-182-F3xx Series Stainless Steel  
Drilled to ANSI-B16.5  
Pressure & Temperature vary with material selected

## Forged Flange (RFSO)

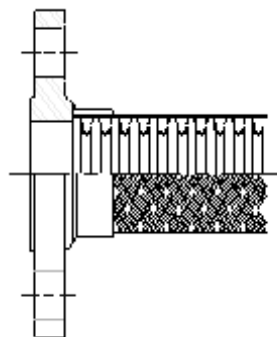

1/4" through 4" (6.4 mm through 101.6 mm) Diameter  
ASTM-A-105 Carbon Steel  
ASTM-A-182-F3xx Series Stainless Steel  
Drilled to ANSI-B16.5  
Pressure & Temperature vary with size and material selected

### Plain Pipe Nipple

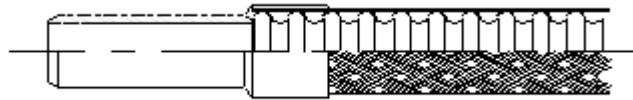

1/4" through 4" (6.4 mm through 101.6 mm) Diameter  
ASTM-A-106B/A53 Carbon Steel ASTM-A-312 Stainless Steel Pipe Sch 40 & 80  
Pressure varies with size and material selected

### Plain Male Nipple

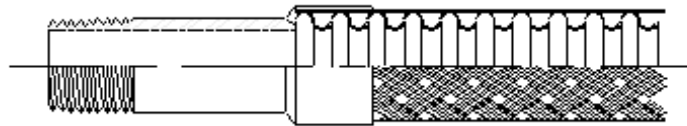

1/4" through 4" (6.4 mm through 101.6 mm) Diameter  
ASTM-A-106B/A53B Carbon Steel  
Pipe Sch 40 & 80  
Pressure varies with size and material selected"

### Female Coupling



1/4" through 4" (6.4 mm through 101.6 mm) Diameter  
ASTM-A-105 Carbon  
ASTM-A-182 Stainless Steel  
Up to 3000 psi  
Temperature varies with service and material selected

### Female Union

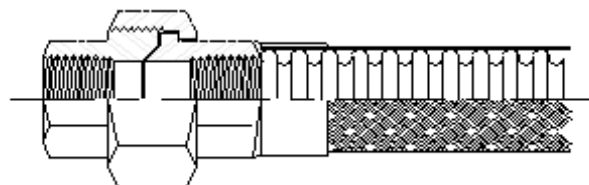

1/4" through 4" (6.4 mm through 101.6 mm) Diameter  
ASTM-A-105 Carbon  
ASTM-A-182 Stainless Steel

Up to 3000 psi  
Temperature varies with service and material selected

**Male Hex Nipple**

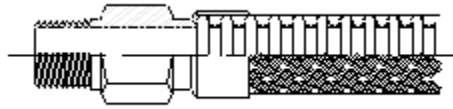

1/4" through 4" (6.4 mm through 101.6 mm) Diameter  
ASTM-A-105 Carbon  
ASTM-A-182 Stainless Steel  
Up to 3000 psi  
Temperature varies with service and material selected

## APPENDIX D – Glossary

**abrasion:** external damage to a hose assembly caused by its being rubbed on a foreign object; a wearing away by friction.

**absorption:** regarding hose, the process of taking in fluid. Hose materials are often compared with regard to relative rates and total amounts of absorption as they pertain to specific fluids.

**accelerated life test:** a method designed to approximate in a short time the deteriorating effects obtained under normal service conditions.

**acid resistant:** having the ability to withstand the action of identified acids within specified limits of concentration and temperature.

**adapter, adaptor:** 1) fittings of various sizes and materials used to change an end fitting from one type to another type or one size to another. (i.e., a male JIC to male pipe adapter is often attached to a female JIC to create a male end union fitting); 2) the grooved portion of a cam & groove coupling.

**adhesion:** the strength of bond between cured rubber surfaces or between a cured rubber surface and a non-rubber surface.

**adhesion failure:** (1) the separation of two bonded surfaces at an interface by a force less than specified in a test method; (2) the separation of two adjoining surfaces due to service conditions.

**afterglow:** in fire resistance testing, the red glow persisting after extinction of the flame.

**Algaflon®:** a registered trademark of Ausimont USA. See PTFE.

**air oven aging:** a means of accelerating a change in the physical properties of rubber compounds by exposing them to the action of air at an elevated temperature at atmospheric pressure.

**air under water testing:** see pneumatic testing.

**ambient temperature:** the temperature of the atmosphere or medium surrounding an object under consideration.

**ambient/atmospheric conditions:** The surrounding conditions, such as temperature, pressure, and corrosion, to which a hose assembly is exposed.

**amplitude of vibrations and/or lateral movement:** the distance a hose assembly deflects laterally to one side from its normal position, when this

deflection occurs on both sides of the normal hose centerline.

**anchor:** a restraint applied to eliminate motion and restrain forces.

**angular displacement:** displacement of two parts defined by an angle.

**annular:** refers to the convolutions on a hose that are a series of complete circles or rings located at right angles to the longitudinal axis of the hose (sometimes referred to as ~~bellows~~).

**anodize, anodized:** an electrolytic process used to deposit protective or cosmetic coatings in a variety of colors on metal, primarily used with aluminum.

**ANSI:** American National Standards Institute.

**anti-static:** see static conductive.

**application working pressure:** unique to customer's application. See pressure, working.

**application:** the service conditions that determine how a hose assembly will be used.

**armor:** a protective cover slid over and affixed to a hose assembly; used to prevent over bending or for the purpose of protecting hose from severe external environmental conditions such as hot materials, abrasion or traffic.

**assembly:** a general term referring to any hose coupled with end fittings of any style attached to one or both ends.

**ASTM:** American Society for Testing and Materials.

**attachment:** the method of securing an end fitting to a hose (e.g., banding, crimping, swaging, or screw-together-2 piece or 3 piece-style-reusable fittings).

**autoclave:** an apparatus using superheated high pressure steam for sterilization, vulcanization and other processes.

**axial movement:** compression or elongation along the longitudinal axis.

**backing:** a soft rubber layer between a hose tube and/or cover and carcass to provide adhesion.

**band:** (1) a metal ring that is welded, shrunk, or cast on the outer surface of a hose nipple or fitting; (2) a thin strip of metal used as a non-bolted clamp. See hose clamp.

**barb:** the portion of a fitting (coupling) that is inserted into the hose, usually comprised of two or more radial serrations or ridges designed to form a redundant seal between the hose and fitting.

**barbed and ferrule fitting:** a two-piece hose fitting comprised of a barbed insert (nipple), normally with peripheral ridges or backward-slanted barbs, for inserting into a hose and a ferrule, usually crimped or swaged.

**basket weave:** a braid pattern in which the plaits of wire alternately cross over and under two strands (two over-two under).

**bench marks:** marks of known separation applied to a specimen used to measure strain (elongation of specimen).

**bench test:** a modified service test in which the service conditions are approximated in the laboratory.

**bend radius:** the radius of a bent section of hose measured to the innermost surface of the curved portion.

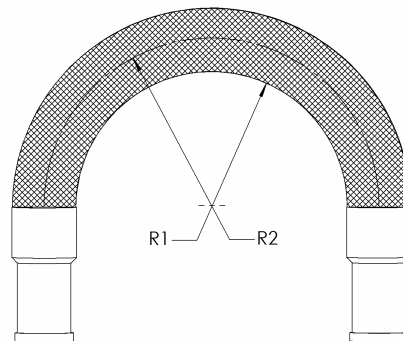

**bend radius, minimum:** the smallest radius at which a hose can be used.

**bend radius, dynamic:** the smallest radius at which constant or continuous flexing occurs.

**bend radius, static:** the smallest fixed radius at which a hose can be subjected.

**bending force:** an amount of stress required to induce bending around a specified radius and hence, a measure of stiffness.

**bevel seat fitting:** see fitting, Bevel Seat.

**Beverly shear:** hand or pneumatically operated, table mounted, metal cutting shear used to cut Fluoropolymer hose



**billet:** (1) a compressed cylinder of Fluoropolymer resin, from which raw tubing is extruded. Also called a preform. (2) a solid piece of material from which a fitting is manufactured.

**bleeding:** surface exudation. See bloom.

**blister:** a raised area on the surface or a separation between layers usually creating a void or air-filled space in a vulcanized article.

**bolt hole circle:** a circle on the flange face around which the center of the bolt holes are distributed.

**bore:** (1) an internal cylindrical passageway, as of a tube, hose or pipe; (2) the internal diameter of a tube, hose, or pipe.

**braid:** the woven portion of a hose used as reinforcement to increase pressure rating and add hoop strength. Various metallic and non-metallic materials are used. A hose may have one or more braids, outside or between layers of hose material.

**braid angle:** the angle developed at the intersection of a braid strand and a line parallel to the axis of a hose.

**braid coverage:** the relative amount of braid material covering a hose expressed as a percent.

**braid make up/construction:** description of braid (i.e., 32-12-.015, T321 SS), where: 32 is the number of carriers; 12 is the number of wires on each carrier; .015 is the wire diameter in inches; and T321 SS is the material, (Type 321 stainless steel).

**braid wear:** motion between the braid and corrugated hose, which normally causes wear on the outside diameter of the corrugation and the inside diameter of the braid.

**braided ply:** a layer of braided reinforcement.

**braid-over-braid:** multiple plies of braid having no separating layers.

**brand:** a mark or symbol identifying or describing a product and/or manufacturer, that is embossed, inlaid or printed.

**brass:** a family of copper/zinc alloys.

**brazing:** a process of joining metals using a non-ferrous filler metal having a melting point that is lower than the parent metals to be joined, typically over +800°F.

**bronze:** an alloy of copper, tin and zinc.

**bunch braid:** braid applied to hose in bundles rather than flat strands (plaits), usually done to achieve high pressure versus hose weight.

**butt weld:** process in which the edges or ends of metal sections are butted together and joined by welding.

**C of C:** certificate of conformance or certificate of compliance; a document, typically signed and dated pertaining to a particular lot or purchase order of item(s), which may involve any standards, specifications, tests, materials and/or performance attributes to which the referenced item(s) have met or will meet.

**cam & groove:** see fitting/coupling - Cam & Groove.

**capped end:** a hose end covered to protect its internal elements.

**carcass:** the fabric, cord and/or metal reinforcing section of a hose as distinguished from the hose tube or cover.

**casing:** see armor.

**cement:** unvulcanized raw or compounded rubber in a suitable solvent used as an adhesive or sealant.

**chafe sleeve:** an outer sleeve providing resistance to chafing and external resistance to damage to braided hoses, available in wide variety of materials to meet the application requirements (e.g., chafe sleeves include slip-on, heat shrinkable, integrally extruded).

**checking:** the short, shallow cracks on the surface of a rubber product resulting from damaging action of environmental conditions.

**chemical compatibility:** the relative degree to which a material may contact another without corrosion, degradation or adverse change of properties.

**chemical resistance:** the ability of a particular polymer, rubber compound, or metal to exhibit minimal physical and/or chemical property changes when in contact with one or more chemicals for a specified length of time, at specified concentrations, pressure, and temperature.

**clamp:** see hose clamp.

**cloth impression:** see fabric impression.

**coefficient of friction:** a relative measure of the surface lubricity.

**cold flex:** see low temperature flexibility.

**cold flexibility:** relative ease of bending while being exposed to specified low temperature.

**cold flow:** continued deformation under stress. See creep.

**collar:** 1) the portion of a fitting that is compressed by swaging or crimping to seal the hose onto the fitting barbs and create a permanent attachment; also called a ferrule. (With reusable fittings, the lock and seal are accomplished mechanically by the collar without swaging or crimping); 2) a raised portion on the hose shank which functions as a connection for a ferrule or other locking device or functions as a hose stop.

**combustible liquid:** a combustible liquid is one having a flash point at or above +100°F (37.8°C).

**compound:** the mixture of rubber or plastic and other materials, which are combined to give the desired properties when, used in the manufacture of a product.

**compression fitting:** see fitting/coupling - Compression

**compression set:** the deformation which remains in rubber after it has been subjected to and released from a specific compressive stress for a definite period of time at a prescribed temperature. (Compression set measurements are for evaluating creep and stress relaxation properties of rubber.)

**concentricity:** the uniformity of hose wall thickness as measured in a plane normal to the axis of the hose.

**conditioning:** the exposure of a specimen under specified conditions, e.g., temperature, humidity, for a specified period of time before testing.

**conductive:** the ability to transfer electrical potential.

**configuration:** the combination of fittings on a particular assembly.

**control:** a product of known characteristics, which is included in a series of tests to provide a basis for evaluation of other products.

**controlled flexing:** occurs when the hose is being flexed regularly, as in the case of connections to moving components (e.g., platen presses, thermal growth in pipe work).

**convoluted:** description of hose or innercore having annular or helical ridges

formed to enhance flexibility.

**convolution count:** the number of ridges or corrugations per inch of a hose.

**copolymer:** a polymer formed from two different monomers.

**core:** the inner portion of a hose, usually referring to the material in contact with the medium.

**corrosion:** the process of material degradation by chemical or electrochemical means.

**corrosion resistance:** ability of metal components to resist oxidation.

**corrugated cover:** a ribbed or grooved exterior.

**coupler:** the female portion of the cam & groove connection with the cam arms.

**coupling:** a frequently used alternative term for fitting.

**cover wear:** the loss of material during use due to abrasion, cutting or gouging.

**cover:** the outer component usually intended to protect the carcass of a product.

**CPE:** chlorinated polyethylene; a rubber elastomer.

**cracking:** a sharp break or fissure in the surface, generally caused by strain and environmental conditions.

**creep:** the deformation, in material under stress, which occurs with lapse of time after the immediate deformation.

**crimp diameter:** the OD of a crimp collar after crimping.

**crimp/crimping:** a fitting attachment method utilizing a number of fingers or dies mounted in a radial configuration. The dies close perpendicular to the hose and fitting axis, compressing the collar, ferrule, or sleeve around the hose.

**cure:** the act of vulcanization. See vulcanization.

**cut off factor:** the hose length to be subtracted from the overall assembly length that allows for the hose coupling end connection extension beyond the end of the hose.

**cut resistant:** having that characteristic of withstanding the cutting action of sharp object.

**cycle-motion:** movement from normal to extreme position and return.

**date code:** any combination of numbers, letters, symbols or other methods used by a manufacturer to identify the time of manufacture of a product.

**deburr:** to remove ragged edges from the inside diameter of a hose end; an important fabrication step for assembling hose of Fluoropolymer in order to insure a good seal.

**deduct length:** the amount of fitting length deducted from a hose to result in the desired finished assembly length.

**design factor:** a ratio used to establish the working pressure of the hose, based on the burst strength of the hose.

**design pressure:** see application working pressure and pressure, working.

**developed length:** see overall length.

**diamond weave:** braid pattern in which the strands alternately cross over one and under one of the strands (one over-one under); also known as ~~plain weave.~~+

**die:** a tool used to swage or crimp a fitting onto a hose. Swage dies usually consist of two halves machined to a predetermined diameter, designed for a specific hose type and size. A crimp die set is typically six to eight ~~ingers.~~ designed for infinite diameter settings within a range or preset to a specific diameter for a given hose type and size.

**dielectric strength:** the maximum voltage required to produce a dielectric breakdown through the material and is expressed as Volts per unit thickness. The higher the dielectric strength of a material the better its quality as an insulator.

**displacement:** the amount of motion applied to a hose defined as inches for parallel offset and degrees for angular misalignment.

**dog-leg assembly:** two hose assemblies joined by a common elbow.

**DOT:** Department of Transportation.

**duplex assembly:** an assembly consisting of two hose assemblies-one inside the other, and connected at the ends; also known as ~~acketed assemblies.~~+

**durometer:** an instrument for measuring the hardness of rubber and plastic compounds.

**durometer hardness:** a numerical value, which indicates the resistance to indentation of the blunt indenter of the durometer.

**dye penetrant inspection/test:** non-destructive inspection method for detecting surface defects.

**dynamic bend radius:** see bend radius, dynamic.

**eccentric wall:** a wall of varying thickness.

**eccentricity:** the condition resulting from the inside and outside diameters not having a common center. See eccentric wall.

**ECTFE:** ethylene-chlorotrifluoroethylene.

**effusion:** the escape, usually of gases, through a material. See permeation.

**elastic limit:** the limiting extent to which a body may be deformed and yet return to its original shape after removal of the deforming force.

**elastic/intermittent flexure:** The smallest radius that a given hose can be bent to without permanent deformation to the metal in its flexing members (convolutions or corrugations).

**elastomer:** any one of a group of polymeric materials, usually designated thermoset, such as natural rubber, or thermoplastic, which will soften with application of heat.

**electrostatic discharge:** the sudden discharge of static electricity from an area of buildup to a grounding point.

**elongation:** the increase in length expressed numerically as a percentage of the initial length.

**encapsulated fitting:** see fitting/coupling-Encapsulated fittings.

**endurance test:** a service or laboratory test, conducted to product failure, usually under normal use conditions.

**EPDM:** Ethylene Propylene Diene Monomer; an elastomer.

**exothermic:** releasing heat.

**extrude/extruded/extrusion:** forced through the shaping die of an extruder; extrusion may have a solid or hollow cross section.

**fabric impression:** impression formed on the rubber surface during vulcanization by contact with fabric jacket or wrapper.

**fabricator:** the producer of hose assemblies.

**fatigue:** the weakening or deterioration of a material occurring when a repetitious or continuous application of stress causes strain, which could lead to failure.

**FDA:** United States Food and Drug Administration.

**FEP:** fluorinated ethylene propylene.

**ferrule:** a metal cylinder placed over a hose end to affix the fitting to the hose. See braid sleeve, interlocking ferrule, and sleeve.

**fire sleeve:** slip-on or integrally extruded sleeve used to retard the effects of fire in certain applications; most often made with silicone and/or ceramic fiber.

**fitting/coupling:** a device attached to the end of the hose to facilitate connection. The following is only a partial list of types of fittings available:

- *Banjo Fitting* - a through bolted design featuring a hollow circle or donut attached to one end of the fitting barb so that the inner diameter is along the hose axis.
- *Butt Weld Fittings* - a hose fitting designed to be permanently welded to a connecting member such as another pipe or a butt weld flange.
- *Cam & Groove Fittings* - a type of fitting that allows connection and disconnection by means of arm(s) or cam(s) on the female fitting. The seal is accomplished by means of a gasket, available in various materials. These fittings are frequently used on product transfer hose assemblies.
- *Compression Fitting* - a fitting style that seals on a mating tube by compressing an internal ferrule against the tube O.D..
- *Encapsulated Fittings* - a metal fitting of various styles usually encased in a thermoplastic or fluoroplastic material by means of molding or coating. Most often done for sanitary purposes or to eliminate corrosion.
- *Field Attachable Fitting* - a fitting designed to be attached to hose without crimping or swaging. This fitting is not always a Reusable type fitting.
- *Flange Retainer Fittings* - a hose fitting flared to a 90° surface, designed to hold a circular rotating flange, such as a slip-on or lap joint style flange.

- *Flange Style Fittings* - pipe flanges and flanged fitting standards are listed under ANSI B16.5. Flanges are rated for pressure and listed as American Class 150, 300, 400, 600, 900, 1,500 or 2,500+. Pressure-Temperature ratings can be obtained by consulting the ANSI specification or ASME B16.5 (American Society of Mechanical Engineers). Designs vary by neck and face style, or other dimensional changes based on use. Various finishes or grooves may be applied to the face for sealing on a gasket or o-ring. Bolt holes and other dimensions are per the ANSI standard.
- *Slip-on Flange* - a flange designed to slip over a flange retainer and float freely in place for bolt alignment. Similar to a lap joint flange except with a very small radius on the face side of the inside diameter to mate with a machined flange retainer. May have a flat or raised face.
- *Lap Joint Flange* - a flange designed to float freely on the flange retainer for bolt alignment. Made with a flat face and having a large radius on the I.D. to mate with a flared pipe style flange retainer.
- *Threaded Flange* - a flange, the inside diameter of which is threaded to attach to a male pipe fitting. A leak proof seal, made with thread sealant, usually does not allow for bolt hole alignment. Inverted Flare Fitting - a fitting consisting of a male or female nut, trapped on a tube by flaring the end of the tube material to either 37° or 45°.
- *JIC Fittings* - joint Industrial Council (no longer in existence). An engineering group that established an industry standard fitting design incorporating a 37° mating surface, male and female styles. These standards now governed by SAE.
- *Lined Fitting* - any fitting of which the wetted surface or entire fitting is covered with a protective material. The covering process may be by spray coating, molding or by inserting hose liner through the I.D. of fitting and anchoring.
- *O-ring Fittings* - a fitting that seals by means of an elastomeric ring of a specified material.
- *Pipe Thread Fittings* -
  - NPT- National Pipe Taper. Pipe thread per ANSI B1.20.1
  - NPTF- National Pipe Tapered for Fuels. Same as above except dry-seal per ANSI B1.20.3
  - NPSH- National Pipe Straight Hose per ANSI B1.20.7



- NPSM- National Pipe Straight Mechanical. Straight thread per ANSI B1.20.1
- NPSL- National Pipe Straight Loosefit per ANSI B1.20.1
- BSPP, BSPT- British Standard Pipe Parallel, British Standard Pipe Taper. BS21.
- *Quick Connect Fitting* - a fitting designed to quickly connect and disconnect. These fittings come in many styles and types.
- *Reusable Fitting* - a fitting designed to be attached and unattached to a hose, allowing all or most of the fitting to be reused.
- *Sanitary Fittings* - a fitting whose seal is accomplished by means of a round gasket in a groove on the face of the fitting. The design eliminates the need for a male and female, since the fitting mates to itself. A re-attachable clamp is also used for coupling.
- *Bevel Seat* - a type of sanitary fitting incorporating a 45° beveled sealing surface. Used in the food and pharmaceutical industries.
- *Split Flange Fitting* - a fitting consisting of a flange retainer and a flange of two halves. This design allows the flanges to be installed after the retainer has been attached to the hose, making the flange reusable. SAE Code 61 and 62.
- *Tube Fitting* - a hose fitting of which the mating end conforms to a tube diameter. The mate or male end of a compression fitting.
- *2-Bolt Flange Fitting* - an elliptical flange with two bolt holes. Typically used in steam applications such as laundry and tire presses.

**flammable gases/liquid/media:** a flammable gas, including liquefied gas, is one having a closed cup flash point below +100°F (+37.8°C) and a vapor pressure greater than 25 psi. (174.2 KPa).

**flat spots:** flat areas on the surface of cured hose caused by deformation during vulcanization.

**flex cracking:** a surface cracking induced by repeated bending and straightening.

**flex life:** the relative ability of an article to withstand constant cycling bending stresses

**flex life test:** a laboratory method used to determine the life of a rubber product when subjected to dynamic bending stresses.

**flow rate:** a volume of media being conveyed in a given time period.

**fluid:** a gas or liquid medium.

**fluid velocity:** the speed of fluid through a cross section expressed in length divided by time.

**fluorocarbon:** an organic compound containing fluorine directly bonded to carbon. The ability of the carbon atom to form a large variety of structural chains gives rise to many fluorocarbons and fluorocarbon derivatives.

**Fluon®:** a registered trademark of Asahi Glass. A term descriptive of the family of fluorocarbons and fluorocarbon derivatives in general commercial use. See PTFE.

**fluoropolymer:** a high molecular weight (long chain) chemical containing fluorine as a major element. Most commonly used but not limited to PTFE, FEP, PFA.

**frequency:** the rate of vibration or flexure in a given time period.

**galvanic corrosion:** corrosion that occurs on the less noble of two dissimilar metals in direct contact with each other in an electrolyte, such as water, sodium chloride in solution, sulfuric acid, etc.

**GMAW:** Gas Metal Arc Weld.

**GPM:** gallons per minute.

**GTAW:** see Tig Weld/GTAW.

**guide (for piping):** a device that supports a pipe radially in all directions, but directs movement.

**Halar®:** Ausimont USA registered trademark. See ECTFE.

**hand built hose:** a hose made by hand on a mandrel, reinforced by textile or wire or combination of both.

**hardness:** resistance to indentation. See durometer hardness.

**heat resistance:** the property or ability to resist the deteriorating effects of elevated temperatures.

**heat-shrink sleeving:** tubular thermoplastic sleeve used for chafe protection or identification. The sleeve is slipped over the hose and shrunk down by the application of heat to fit tightly on the hose.

**helical wire armor/spring guard:** an abrasion resistance device.

**helical:** used to describe a type of corrugated hose having one continuous convolution resembling a screw thread.

**helix:** a shape formed by spiraling a wire or other reinforcement around the cylindrical body of a hose; typically used in suction hose.

**hoop strength:** the relative measure of a hose's resistance to collapse of the diameter perpendicular to the hose axis.

**hose:** a flexible conduit consisting of a tube, reinforcement, and usually an outer cover.

**hose assembly:** see assembly.

**hose clamp:** a device used to hold a hose onto a fitting.

**Hostaflon®:** a registered trademark of Dyneon. See PFA.

**hydrostatic testing:** the use of liquid pressure to test a hose or hose assembly for leakage, twisting, and/or hose change-in-length.

**Hypalon®:** a DuPont registered trademark. See CSM.

**Hytrel®:** a DuPont registered trademark.

**I.D.:** the abbreviation for inside diameter.

**identification yarn:** a yarn of single or multiple colors, usually embedded in the hose wall, used to identify the manufacturer.

**impression:** a design formed during vulcanization in the surface of a hose by a method of transfer, such as fabric impression or molded impression.

**impulse service:** an application parameter characterized by continuous cyclical pressure changes from low to high.

**impulse:** an application of force in a manner to produce sudden strain or motion, such as hydraulic pressure applied in a hose.

**indentation:** 1) the extent of deformation by the indenter point of any one of a number

of standard hardness testing instruments; 2) a recess in the surface of a hose.

**innercore:** the innermost layer of a hose; the hose material in contact with the medium.

**insert:** optional term for nipple. See nipple.

**interlocked hose:** formed from profiled strip and wound into flexible metal tubing with no subsequent welding, brazing, or soldering; may be made pressure-tight by winding in strands of packing.(see also Armor)

**interlocking ferrule:** a ferrule, which physically attaches to the fitting preventing the ferrule from sliding off the fitting.

**interstice:** a small opening, such as between fibers in a cord or threads in a woven or braided fabric.

**IPT:** iron pipe threads; a reference to NPT or NPTF.

**ISO:** International Organization for Standardization.

**jacket:** a seamless tubular braided or woven ply generally on the outside of a hose.

**JIC:** see fitting/coupling-JIC.

**Jacketed assemblies;** See duplex assemblies

**kinking:** a temporary or permanent distortion of the hose induced by bending beyond the minimum bend radius.

**Kynar®:** ELF Atochem registered trademark. See PVDF.

**lap seam:** a seam made by placing the edge of one piece of material extending flat over the edge of the second piece of material.

**lay:** 1) the direction of advance of any point in a strand for one complete turn; (2) the amount of advance of any point in a strand for one complete turn. See pitch.

**layer:** a single thickness of rubber or fabric between adjacent parts.

**leaker:** 1) a crack or hole in the tube which allows fluids to escape; 2) a hose assembly which allows fluids to escape at the fittings or couplings.

**life test:** a laboratory procedure used to determine the resistance of a hose to a specific set of destructive forces or conditions. See accelerated life test.

**light resistance:** the ability to retard the deleterious action of light.

**lined bolt holes:** the bolt holes, which have been given a protective coating to cover the internal structure.

**liner:** flexible sleeve used to line the inside diameter of hose when conveying a high velocity media, also prevents erosion.

**live length:** the lineal measurement of hose between couplings.

**LJF (lap joint flange):** see fitting/coupling - Lap Joint Flange.

**loop installation:** the assembly is installed in a loop or  $\omega$ -shape, and is most often used when frequent and/or large amounts of motion are involved.

**low temperature flexibility:** the ability of a hose to be flexed, bent or bowed at low temperatures without loss of serviceability.

**LPG, LP Gas:** the abbreviation for liquefied petroleum gas.

**MAWP:** see pressure, maximum allowable working.

**mandrel:** 1) a form, generally of elongated round section used for size and to support hose during fabrications and/or vulcanization. It may be rigid or flexible; 2) a tapered expanding device, fixed in diameter, which is pulled through a shank of a fitting thus expanding the diameter to exert force on the hose between the shank and ferrule.

**mandrel built:** a hose fabricated and/or vulcanized on a mandrel.

**mandrel, flexible:** a long, round, smooth rod capable of being coiled in a small diameter. It is used for support during the manufacture of certain types of hose. (The mandrel is made of rubber or plastic material and may have a core of flexible wire to prevent stretching.)

**mandrel, rigid:** a non-flexible cylindrical form on which a hose may be manufactured.

**manufacturer's identification:** a code symbol used on or in some hose to indicate the manufacturer.

**mass flow rate:** the mass of fluid per unit of time passing through a given cross-section of a flow passage in a given direction.

**mean diameter:** the midpoint between the inside diameter and the outside diameter of a corrugated/convoluted hose.

**mechanical fitting/reusable fitting:** a fitting attached to a hose, which can be disassembled and used again.

**media, medium:** the substance(s) being conveyed through a system.

**melder:** a fitting or device used to join two sections of hose.

**misalignment:** a condition where two parts do not meet true.

**monomer;** a small molecule that may become chemically bonded to other monomers to form a polymer

**NAHAD:** the abbreviation for the National Association of Hose & Accessories Distributors.

**necking down:** a localized decrease in the cross-sectional area of a hose resulting from tension.

**Neoflon®:** a registered trademark of Daikin USA.

**Neoprene®:** a registered trademark of DuPont.

**nipple:** the internal member or portion of a hose fitting.

**nitrile rubber (NB/Buna-N):** a family of acrylonitrile elastomers used extensively for industrial hose.

**nominal:** a size indicator for reference only.(see chart)

<b>Nominal Size</b>	Dash Size	-3	-4	-6	-8	-12	-16	-20
<b>Smooth Bore</b>	ID inches	1/8	3/16	5/16	7/16	5/8	7/8	1 1/8

<b>True Bore Size</b>	Dash Size	-5	-6T or -7	-10	-12T or -14	-16T or -18
<b>Smooth Bore</b>	ID inches	1/4	3/8	1/2	3/4	1

**nomograph:** a chart used to compare hose size to flow rate to recommended velocity.

**non-conductive:** the inability to transfer an electrical charge.

**non-interlocking ferrule:** see sleeve.

**NPT/NPTF:** abbreviation for national pipe threads. See fitting/coupling - Pipe Thread Fittings.

**nylon:** a family of polyamide materials.

**OAL:** see overall length

**O.D.:** the abbreviation for outside diameter.

**OE/OEM:** original equipment manufacturer.

**off-center:** see eccentricity.

**offset-lateral, parallel:** the distance that the ends of a hose assembly are displaced in relation to each other as the result of connecting two misaligned terminations in a system, or intermittent flexure required in a hose application.

**oil resistance:** the ability of the materials to withstand exposure to oil.

**operating conditions:** the pressure, temperature, motion, and environment to which a hose assembly is subjected.

**o-ring fitting:** see fitting/coupling, O-Ring.

**overall length (OAL):** the total length of a hose assembly, which consists of the free hose length plus the length of the coupling(s).

**oxidation:** the reaction of oxygen on a material, usually evidenced by a change in the appearance or feel of the surface or by a change in physical properties.

**ozone cracking:** the surface cracks, checks or crazing caused by exposure to an atmosphere containing ozone.

**ozone resistance:** the ability to withstand the deteriorating effects of ozone (generally cracking).

**PFA:** perfluoralkoxy

**penetration (weld):** the percentage of wall thickness of the two parts to be joined that is fused into the weld pool in making a joint.

**performance test (service test):** a test in which the product is used under actual service conditions.

**permanent fitting:** the type of fitting which, once installed, may not be removed for re-use.

**permeation:** the process of migration of a substance into and through another, usually the movement of a gas into and through a hose material; the rate of permeation is specific to the substance, temperature, pressure and the material being permeated.

**Pharmacopeia Class VI:** The testing of elastomers, plastics, polymeric materials and their extracts as described in the U.S. Pharmacopeia General Chapter <88>. This in vivo testing consists of three (3) tests: Systemic, Intracutaneous, and Implantation. The materials and their extracts are then classified according to the test results as meeting Plastics Class I through Class VI

**pick:** the distance across a group of braid wires from a single carrier, measured along the axis of the hose.

**pig:** a mechanical projectile used for cleaning hose.

**pin pricked:** perforations through the cover of a hose to vent permeating gases.

**pitch:** 1) the distance from one point on a helix to the corresponding point on the next turn of the helix, measured parallel to the axis; 2) the distance between the two peaks of adjacent corrugation or convolution.

**plain ends:** fitting ends without threads, groove, or a bevel typically used for welding, as in a flange.

**plaits:** an individual group of reinforcing braid wires/strands.

**plating:** a material, usually metal, applied to another metal by electroplating, for the purpose of reducing corrosion; typically a more noble metal such a zinc is applied to steel.

**ply:** an individual layer in hose construction.

**pneumatic testing:** the use of compressed air to test a hose or hose assembly for leakage, twisting, and/or hose change-in-length. NOTE: Use of high pressure air is extremely hazardous.

**Polyflon®:** a registered trademark of Daikin USA. See PTFE.

**polymer:** a macromolecular material formed by the chemical combination of monomers, having either the same or different chemical compositions.

**post-sinter:** the technique of re-heating PTFE innercore to process temperature in order to reduce permeability.

**preform:** the compressed cylinder of PTFE resin that is used to extrude into raw tubing. Also called a billet.

**pre-production inspection or test:** the examination of samples from a trial run of hose to determine adherence to a given specification, for approval to produce.



**preset:** the process of pressurizing a hose to set the braid and minimize length change in final product.

**pressure:** force ÷ unit area. For purposes of this document, refers to PSIG (pounds per square inch gauge).

**pressure drop:** the measure of pressure reduction or loss over a specific length of hose.

**pressure, burst:** the pressure at which rupture occurs.

**pressure, deformation:** the pressure at which the convolutions of a hose become deformed.

**pressure, gauge:** relative pressure between inside and outside of an assembly.

**pressure, maximum allowable working:** the maximum pressure at which a hose or hose assembly is designed to be used.

**pressure, operating:** see pressure, working.

**pressure, proof test:** a non-destructive pressure test applied to hose assemblies.

**pressure, pulsating:** a rapid change in pressure above and below the normal base pressure, usually associated with reciprocating type pumps.

**pressure, rated working:** see pressure, maximum allowable working.

**pressure, service:** see working pressure.

**pressure, shock/spike:** the peak value of a sudden increase of pressure in a hydraulic or pneumatic system producing a shock wave.

**pressure, working:** the maximum pressure to which a hose will be subjected, including the momentary surges in pressure, which can occur during service. Abbreviated as WP.

**printed brand:** see brand.

**profile:** the finished shape of a corrugation/convolution.

**propane:** see LPG, LP Gas.

**psi:** pounds per square inch.

**PTFE:** polytetrafluoroethylene, a high molecular weight fluoroplastic polymer with carbon atoms shielded by fluorine atoms having very strong inter atomic bonds, giving it chemical inertness.

**pull off force:** the force required to pull the hose from its attachment not generated by the internal pressure.

**PVC:** polyvinyl chloride.

**PVDF:** polyvinylidene fluoride.

**quality conformance inspection or test:** the examination of samples from a production run of hose to determine adherence to given specifications, for acceptance of that production.

**random motion:** the uncontrolled motion of a metal hose, such as occurs in manual handling.

**reinforcement:** the strengthening members, consisting of either fabric, cord, and/or metal, of a hose. See ply.

**reusable fitting/coupling:** see fitting/coupling, reusable.

**SAE:** Society of Automotive Engineers.

**safety factor:** see design factor.

**sampling:** a process of selecting a portion of a quantity for testing or inspection, selected without regard to quality.

**Santoprene®:** a thermoplastic elastomer and a registered trademark of Advanced Elastomer Systems.

**serrations:** bumps, barbs, corrugations, or other features that increase the holding power of the device.

**service temperature:** see working temperature.

**shank:** that portion of a fitting, which is inserted into the bore of a hose.

**shelf/storage life:** the period of time prior to use during which a product retains its intended performance capability.

**shell:** see ferrule.

**shock load:** a stress created by a sudden force.

**simulated service test:** see bench test.

**skive:** the removal of a short length of cover and/or tube to permit the attachment of a fitting directly over the hose reinforcement.

**sleeve:** a metal cylinder, which is not physically attached to the fitting, for the purpose of forcing the hose into the serrations of the fitting.

**smooth bore:** a term used to describe the type of innercore in a hose.

**socket:** the external member or portion of a hose fitting, commonly used in describing screw-together reusable fittings.

**specification:** a document setting forth pertinent details of a product.

**spiral:** a method of applying reinforcement in which there is not interlacing between individual strands of the reinforcement.

**spiral angle:** the angle developed by the intersection of the helical strand and a line parallel to the axis of a hose. See braid angle.

**spring guard:** a helically wound component applied internally or externally to a hose assembly, used for strain relief, abrasion resistance, collapse resistance.

**squirm:** a form of failure where the hose is deformed into an S- or U-bend, as the result of excessive internal pressure being applied to unbraided corrugated hose while its ends are restrained or in a braided corrugated hose which has been axially compressed.

**standard:** a document, or an object for physical comparison, for defining product characteristics, products, or processes, prepared by a consensus of a properly constituted group of those substantially affected and having the qualifications to prepare the standard for use.

**static bonding:** use of a grounded conductive material between fittings to eliminate static electrical charges.

**static conductive:** having the capability of furnishing a path for a flow of static electricity.

**static discharge:** see electrostatic discharge.

**static wire:** wire incorporated in a hose to conduct static electricity.

**stem:** see nipple.

**stress corrosion:** a form of corrosion in metal.

**surge (spike):** a rapid and transient rise in pressure.

**swage:** the method of fitting attachment that incorporates a set of die halves designed to progressively reduce the collar or ferrule diameter to the required finish dimension by mechanically forcing the fitting into the mating die.

**swelling:** an increase in volume or linear dimension of a specimen immersed in liquid or exposed to a vapor.

**tape wrapped convoluted:** a type of flexible hose incorporating layers of tape to form helical ridges and grooves.

**tear resistance:** the property of a rubber tube or cover of a hose to resist tearing forces.

**Teflon®:** a registered trademark of E.I. DuPont. See PTFE, FEP and PFA.

**tig weld/GTAW:** the gas tungsten arc welding process sometimes referred to as shielded arc or heliarc.

**traveling loop, Class A Loop:** an application wherein the radius remains constant and one end of the hose moves parallel to the other end.

**traveling loop, Class B Loop:** a condition wherein a hose is installed in a U-shaped configuration and the ends move perpendicular to each other so as to enlarge or decrease the width of the loop.

**tube:** the innermost continuous all-rubber or plastic element of a hose.

**tube fitting:** see fitting/coupling-Tube.

**tubing:** a non-reinforced, homogeneous conduit, generally of circular cross-section.

**twist:** (1) the turns about the axis, per unit of length, of a fiber, roving yarn, cord, etc. Twist is usually expressed as turns per inch; (2) the turn about the axis of a hose subjected to internal pressure.

**unsintered:** material that has not undergone primary heat processing.

**vacuum formed convoluted:** smooth bore hose that is made flexible by the formation of ridges and grooves during a process that utilizes heat and vacuum to mechanically form convolutions.

**vacuum resistance:** the measure of a hoses ability to resist negative gauge pressure.

**velocity resonance:** vibration due to the buffeting of a high velocity gas or liquid flow.

**vibration:** amplitude motion occurring at a given frequency.

**viscosity:** the resistance of a material to flow.

**volume change:** a change in dimensions of a specimen due to exposure to a liquid or vapor.

**volume swell:** see swelling.

**volumetric expansion:** the volume increase of hose when subjected to internal pressure.

**vulcanization:** a process during which a rubber compound, through a change in its chemical structure, improves or extends elastic properties over a greater range of temperature.

**weathering:** the surface deterioration of a hose cover during outdoor exposure, as shown by checking, cracking, crazing and chalking.

**wire reinforced:** a hose containing wires to give added strength, increased dimensional stability; crush resistance. See reinforcement.

**working temperature:** the temperature range of the application, may include the temperature of the fluid conveyed or the environmental conditions the assembly is exposed to in use.

**WP:** the abbreviation for working pressure.

**wrapped cure:** a vulcanizing process using a tensioned wrapper (usually of fabric) to apply external pressure.

*The preceding Glossary of Terms, as utilized in the hose industry, includes some definitions from The Hose Handbook, published by the Rubber Manufacturers Association.*

**NOTES:**

---

---

---

---

---

---

---

---

---

---

---

---

---

---

---

---

---

---

---

---

---

---

---